

**THE CONSTITUTION  
AND BYLAWS  
AND ELIGIBILITY CODE**

---

**THE TAU BETA PI  
ASSOCIATION, INC.**

**TBP**

**2011**



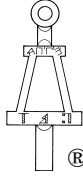

As Enacted June 6, 1966  
Last Amended October 2011

CONTENTS

THE ELIGIBILITY CODE ..... iv

CONSTITUTION

	<i>Page</i>		<i>Page</i>
PREAMBLE .....	1	<b>Article IV—Association Officers and Directors</b>	
		SECTION:	
<b>Article I—Name, Motto, Insignia, Ritual, Creed, Language, and Currency</b>		1. Association Officers and Directors ...	6
SECTION:		2. Designation and Duties .....	6
1. Name .....	1	3. Vacancy .....	8
2. Motto .....	1	4. Indemnification .....	8
3. Insignia .....	1	5. Bond .....	8
4. Badge .....	2		
5. Auxiliary Jewelry .....	2	<b>Article V—Retirement Provisions</b>	
6. Jewelry Standardization .....	3	SECTION:	
7. Use of Insignia Replica.....	3	1. Coverage .....	8
8. Ritual .....	3	2. Payments for Secretary-Treasurer and Assistant Secretary-Treasurer ....	8
9. Creed .....	3	3. Payments for Other Employees .....	8
10. Language .....	3	4. Secretary-Treasurers Emeritus .....	9
11. Currency .....	3		
		<b>Article VI—Collegiate Chapters</b>	
<b>Article II—Organization of the Association</b>		SECTION:	
SECTION:		1. Chapter Membership.....	9
1. Chapters .....	3	2. Petition for Chapter.....	9
2. Districts .....	3	3. Vote on Chapters.....	9
3. Headquarters .....	3	4. Installation .....	10
		5. Control .....	10
<b>Article III—Government of the Association</b>		6. Officers .....	10
SECTION:		7. Advisory Board .....	10
1. Governing Bodies .....	4	8. Proxy .....	10
2. Convention .....	4	9. Meetings .....	10
3. Executive Council .....	4		
4. Council Officers .....	5	<b>Article VII—Alumnus Chapters</b>	
5. Council Responsibilities .....	5	SECTION:	
6. Council Vacancy .....	6	1. Application and Membership .....	10
7. Fiscal Year .....	6	2. Officers .....	11
		3. Duties .....	11
		4. Convention Representation .....	11
		5. District Activities .....	11

	<i>Page</i>
<b>Article VIII—Membership</b>	
SECTION:	
1. Election .....	11
2. Eligibility of Undergraduates.....	11
3. Eligibility of Graduate Students..	13
4. Eligibility of Alumni of Own Institution .....	13
5. Eligibility of Alumni of Other Institutions .....	14
6. Eligibility of Eminent Engineers	14
7. Eligibility Requirements for Alumni and Eminent Engineers..	14
8. Other Memberships.....	15
9. Resignation .....	15
10. Financial Inability .....	15
11. Initiation by Error .....	15

<b>Article IX—Discipline</b>	
SECTION:	
1. Methods for Chapters .....	16
2. Procedures for Chapters .....	16
3. Fines on Chapters .....	16
4. Methods for Members .....	16
5. Procedures for Members .....	16

<b>Article X—BENT Life Subscription Fund</b>	
SECTION:	
1. Basis and Use .....	17
2. Administration .....	17

<b>Article XI—Fellowship Fund</b>	
SECTION:	
1. Basis and Use.....	17
2. Administration .....	17

<b>Article XII—Convention Fund</b>	
SECTION:	
1. Basis and Use .....	17
2. Administration .....	17

<b>Article XIII—Student Loan Fund</b>	
SECTION:	

	<i>Page</i>
1. Source and Purpose .....	17
2. Rate of Interest and Disposition..	18

<b>Article XIV—Contingency Fund</b>	
SECTION:	
1. Purpose and Amount .....	18
2. Management .....	18
3. Investment .....	18

<b>Article XV—Engineering Futures Fund</b>	
SECTION:	
1. Basis and Use .....	18
2. Administration .....	18

<b>Article XVI—Scholarship Fund</b>	
SECTION:	
1. Basis and Use .....	18
2. Administration .....	18

<b>Article XVII—Investment Requirements</b>	
SECTION:	
1. Specific Funds .....	18
2. Trustee .....	19
3. Trustee Responsibilities .....	19
4. Investment Objectives .....	19
5. Trust Advisory Committee .....	19
6. Nonconurrence .....	19
7. Guiding Rule.....	19
8. Review Committee .....	20
9. Investments by Officers .....	20

<b>Article XVIII—Amendments</b>	
SECTION:	
1. Proposal .....	20
2. Adoption .....	20
3. Time Limit of Chapter Vote .....	20
4. Report .....	20

<b>Article XIX—Enactment</b>	21
------------------------------	----

<b>Article XX—Merger of Sigma Tau into the Association</b>	21
--	----

**BYLAWS**

<b>Bylaw I—The Convention</b>	
SECTION:	
1.01. Assembly .....	22
1.02. Order of Business .....	22
1.03. Minutes of the Convention.....	22
1.04. Delegates .....	22
1.05. Assessments .....	22
1.06. Delegate’s Expense Report.....	22
1.07. Model Initiation .....	23
1.08. Privilege of Member .....	23
1.09. Suspension of Bylaws .....	23
1.10. Rules of Order .....	23

**Bylaw II—The Executive Council**

SECTION:	
2.01. Meetings .....	23
2.02. Chapter Actions on Comm. ...	23
2.03. Report to Convention .....	24

<b>Bylaw III—Association Officers</b>	
SECTION:	
3.01. Secretary-Treasurer .....	24
3.02. Asst. Secretary-Treasurer.....	25
3.03. Director of Rituals .....	26
3.04. Director of Fellowships.....	26
3.05. District Directors.....	26
3.06. Director of Eng’g. Futures .....	26

	<i>Page</i>
<b>Bylaw IV—Establishment of Collegiate Chapters</b>	
SECTION:	
4.01. Petition .....	26
4.02. Inspection .....	27
<b>Bylaw V—Collegiate Chapters</b>	
SECTION:	
5.01. Election of Officers .....	27
5.02. Standing Committees .....	28
5.03. Duties of Officers .....	28
5.04. Chapter Finances.....	29
5.05. Convention Delegate .....	29
5.06. District Activities .....	30
5.07. Quorum .....	30
<b>Bylaw VI—Election of Members</b>	
SECTION:	
6.01. Election Periods .....	30
6.02. Compilation of Data.....	30
6.03. Election .....	31
6.04. Revocation of Election.....	32
6.05. Records and Reports .....	32
6.06. Inactive Status .....	33
6.07. Transfer of Chapter .....	33
6.08. Payments by Active Members.	33
<b>Bylaw VII—Initiation</b>	
SECTION:	
7.01. Electee Activities .....	33
7.02. Electee Duties .....	33
7.03. Constitution and Bylaws .....	34
7.04. Initiation Fee .....	34
7.05. Roll Book .....	34
7.06. Certificate and Badge .....	34
7.07. Reports .....	34
7.08. Joint Activities .....	34
7.09. Initiation Postponement .....	34
<b>Bylaw VIII—Fines</b>	
SECTION:	
8.01. Failure to Report .....	34
8.02. Unapproved Initiation .....	35
8.03. Initiation of Inelig. Candidate	35
8.04. Lack of Proof of Worthiness	35
8.05. Failure to File .....	35
8.06. Failure to Comply .....	35
8.07. Application .....	35
8.08. Deadlines .....	35
<b>Bylaw IX—Publications</b>	
SECTION:	
9.01. Names .....	35
9.02. Editor .....	36
9.03. Publication Schedule.....	36
9.04. Subscription Fee.....	36
9.05. Life Subscription Fund .....	36

	<i>Page</i>
<b>Bylaw X—Fellowships</b>	
SECTION:	
10.01. Establishment.....	36
10.02. Objective .....	36
10.03. Eligibility Conditions.....	37
10.04. Selection Criteria .....	37
10.05. Certificate.....	37
10.06. Resignation .....	37
10.07. Payment.....	37
10.08. Report of Fellows.....	37
10.09. Rules for Application.....	37
<b>Bylaw XI—Scholarships</b>	
SECTION:	
11.01. Establishment.....	38
11.02. Objective .....	38
11.03. Eligibility Conditions.....	38
11.04. Selection Criteria .....	38
11.05. Certificate.....	38
11.06. Resignation .....	38
11.07. Payment.....	38
11.08. Rules for Application.....	38
<b>Bylaw XII—Laureates</b>	
SECTION:	
12.01. Objective .....	39
12.02. Basis for Nomination .....	39
12.03. Nominations .....	39
12.04. Selection Committee.....	39
12.05. Award and Recognition .....	39
12.06. Relationship to Other Awards	39
<b>Bylaw XIII—Student Loans</b>	
SECTION:	
13.01. Administration .....	39
13.02. Application.....	39
13.03. Approval .....	39
13.04. Payment .....	40
13.05. Rules and Regulations .....	40
<b>Bylaw XIV—Engineering Futures</b>	
SECTION:	
14.01. Objective .....	40
14.02. Curriculum .....	40
14.03. Facilitators .....	40
14.04. Presentations .....	40
14.05. Restrictions .....	40
<b>Bylaw XV—Amendments</b>	
SECTION:	
15.01. Proposal .....	40
15.02. Adoption .....	40
15.03. Report on Amendment .....	41
15.04. Restriction .....	41
<b>Bylaw XVI—Dissolution</b> .....	41

# THE ELIGIBILITY CODE OF THE TAU BETA PI ASSOCIATION

*(Adopted by the 1926 Convention)*

In order that there may be a more uniform basis for selection of members for Tau Beta Pi, these suggestions are offered. It is expected that a copy of this statement be given each active member before every election, and it may at times serve as a general expression of our policy in the selection of members.

It is the purpose of the Society to mark in a fitting manner those who have conferred honor upon their alma mater by distinguished scholarship and exemplary character as students, or by their attainments as alumni.

Distinguished scholarship, while the primary requisite for admission, must not be considered the sole criterion.

After the scholastic requirements have been fulfilled, the selection shall be based on integrity, breadth of interest both inside and outside of engineering, adaptability, and unselfish activity.

We consider that true integrity is the *sine qua non* for membership in Tau Beta Pi, that it transcends in importance scholarship, activity, and every other qualification. Without private and public integrity, we believe that no organization is worthy of existence. Under integrity, we include honor and high standards of truth and justice.

Breadth of interest sufficient for eligibility in this Association will enable people to maintain their positions in their community by the exercise of qualities other than engineering ability.

True engineers must be able to adapt themselves ingeniously to all circumstances and conditions, making them conform to the desired purpose.

The rating of people on the degree of unselfish activity manifested, is intended to indicate that Tau Beta Pi believes that none can become worthy engineers without the welfare of associates, organizations, and the community at heart. It is furthermore expected that they display willingness to aid and assist in worthy causes by their actual campus record. However, the fact that people may not have shown unselfish activity to an appreciable degree throughout their courses of study is no infallible indication that they would not if the opportunity offered. The most conspicuous illustrations of this are those students who are self supporting, for which due allowance must be made and due credit given. In fine, it is in this capacity for the unstinted giving of their best, without thought of remuneration, that we believe lies one of the most sensitive tests for determining candidates' rights to bear the name and wear the Bent of Tau Beta Pi.

# THE CONSTITUTION OF THE TAU BETA PI ASSOCIATION<sup>1</sup>

## PREAMBLE

The **Tau Beta Pi Association** was founded at Lehigh University in 1885 by Edward Higginson Williams, Jr.,<sup>2</sup> to mark in a fitting manner those who have conferred honor upon their Alma Mater by distinguished scholarship and exemplary character as students in engineering, or by their attainments as alumni in the field of engineering, and to foster a spirit of liberal culture in engineering colleges. To carry out the purposes and objects of this Association, we do hereby ordain and enact the following:

## CONSTITUTION

### Article I

#### *Name, Motto, Insignia, Ritual, Creed, Language, and Currency*

SECTION 1. **Name.** The name of this corporation shall be THE TAU BETA PI ASSOCIATION, hereafter referred to as the "Association."

SECTION 2. **Motto.** The motto, symbolized by



shall not be made public, but, with the rituals, shall be handed down traditionally.

SECTION 3. **Insignia.** (a) The official colors of the Association shall be seal brown and white.

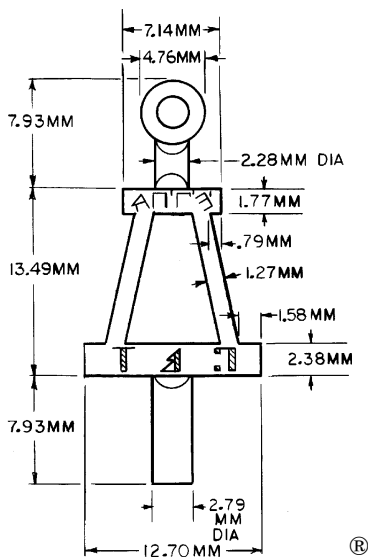

Figure 1

<sup>1</sup>Incorporated in 1947 under laws of the State of Tennessee. Name registered in U.S. Patent Office.

C-I, 3(b)

<sup>2</sup> Born in Proctorsville, Vermont, Sept. 30, 1849; died in Woodstock, Vermont, Nov. 2, 1933.

(b) The official emblem of the Association shall represent a bent of a trestle. It shall be called the Bent of Tau Beta Pi.

(c) The official badge of the Association shall be a watch-key, shaped like the bent of a trestle. The body of the key shall be 1/16" (0.16 cm) thick, and it shall have the dimensions shown in Figure 1. The symbols shall be engraved on the face of the key in the manner and form indicated in the figure. The reverse of the key shall have engraved on the cap of the Bent the name of the electing chapter (state and Greek letter) and on the sill of the Bent the name of the owner and the year of graduation of the member's class at the time of initiation.

(d) The official flag of the Association shall consist of three equal vertical stripes, the two end ones of seal brown and the center one of white bearing a Bent in seal brown. The flag shall be two units high and three units long. The Bent on the center stripe shall be 1 1/4 units high and of the proportions shown in Figure 1.

(e) The official certificate of membership shall be as shown in Figure 2. Chapters may, at their discretion, issue certificates in their native language in addition to the official certificate.

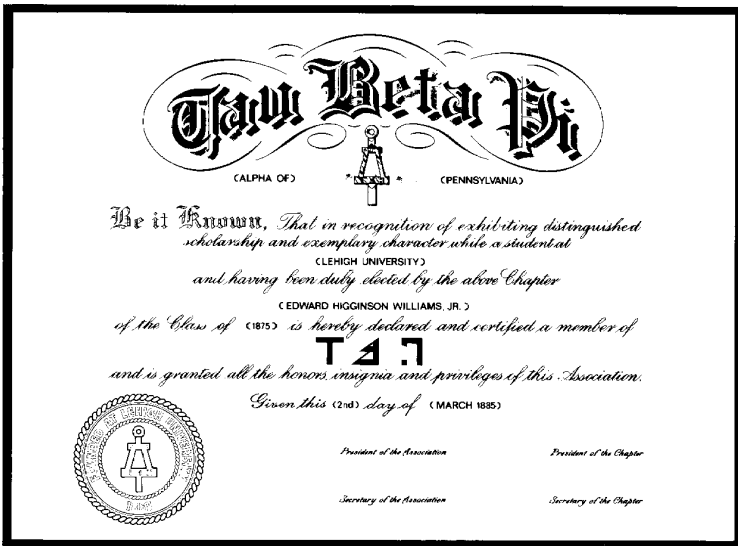

(Words in parentheses to be changed to suit the chapter, etc.)

Figure 2

(f) The certificate of membership for those elected under Article VIII, Section 6, of this Constitution shall be prescribed by the Executive Council.

(g) The official seal of the Association shall be as shown in Figure 3.

**SECTION 4. Badge.** The official badge of the Association shall be worn only by members of the Association.

**SECTION 5. Auxiliary Jewelry.** Jewelry bearing a replica of the official badge of the Association, to be worn by members, shall be limited to articles manufactured for the Association; and Tau Beta Pi jewelry to be worn by relatives of members shall be limited to a miniature badge.

Figure 3

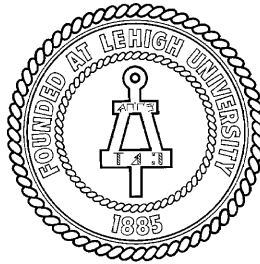

**SECTION 6. Jewelry Standardization.** Auxiliary jewelry as specified in Section 5 shall be standardized and approved by the Executive Council. The official badge and auxiliary jewelry shall be purchased only from an official jeweler through the Secretary-Treasurer of the Association.

**SECTION 7. Use of Insignia Replica.** Replicas of the badge or other insignia of the Association shall not be used unless authorized by the Executive Council.

**SECTION 8. Ritual.** The initiation ritual to be used by all Chapters shall be approved by the Convention and shall be kept secret. The Convention shall designate portions of this ritual as mandatory or optional. Portions designated as optional may be omitted by a Chapter with prior approval of the Chapter's Advisory Board. Any exception to the above requires approval of the Executive Council. Copies of the ritual shall be prepared only by a member of the Association. When copies of the ritual become obsolete or badly worn, they shall be destroyed. See Const. Art. IV, Sec. 2(g)(1).

**SECTION 9. Creed.** The creed of Tau Beta Pi shall be "Integrity and Excellence in Engineering."

**SECTION 10. Language.** All correspondence with and business of the Association shall be in English. See Const. Art. VI, Sec. 5.

**SECTION 11. Currency.** All financial transactions with the headquarters of the Association shall be in U.S. dollars. See Const. Art. VI, Sec. 5.

## Article II

### *Organization of the Association*

**SECTION 1. Chapters.** This Association shall consist of Collegiate Chapters that have been established in colleges and universities and Alumnus Chapters that have been established in convenient locations. The first Collegiate Chapter of each state or territory shall be designated by the Greek letter Alpha, the second by Beta, and so on, following the name of the state or territory where located. International chapters shall be named in a similar fashion as deemed appropriate by the Executive Council. After the letter Omega is reached, naming shall continue as Alpha Alpha, Alpha Beta, and so on. An Alumnus Chapter shall be known by the name submitted with the Charter application, subject to the approval of the Executive Council.

**SECTION 2. Districts.** The Chapters shall be assigned to geographical Districts the number of which shall be determined by the Executive Council. The Council may change the assignments of Chapters and the number of Districts from time to time as circumstances indicate.

**SECTION 3. Headquarters.** The headquarters of the Association shall be located at the office of the Secretary-Treasurer of the Association.

### Article III

#### *Government of the Association*

**SECTION 1. Governing Bodies.** The Association shall be governed by the Convention and the Executive Council. These two bodies shall control all matters and affairs pertaining to the Association as a whole but shall not interfere with the internal affairs of any Chapter, except in matters of discipline as hereinafter provided.

**SECTION 2. Convention.** (a) The Convention shall meet annually except as provided in Sections 5(f) and (g) of this Article and shall be composed of one delegate from each Chapter (Collegiate and Alumnus), the members of the Executive Council, the Secretary-Treasurer, the Assistant Secretary-Treasurer, the Director of Rituals, the Director of Fellowships, the Director of Engineering Futures, and one Director per District who shall be entitled to one vote each. Proxies shall not be permitted. A Chapter delegate shall represent only one Chapter. An individual person shall not be entitled to more than one vote. Representatives of a majority of the Collegiate Chapters shall constitute a quorum.

(b) The Secretary-Treasurer of the Association shall, prior to the Convention, appoint an appropriate number of delegates to the following Committees: (1) Petitions, (2) Constitution and Bylaws, (3) Chapter and Association Financial Affairs, (4) Rituals, (5) Convention Site, (6) Resolutions, (7) Awards, and such other Committees as the Executive Council may authorize. One or more Officers or Directors of the Association shall be appointed to act as advisor(s) to each Committee. These Committees shall meet on the first day of the Convention to consider the respective subjects and later shall present their reports to the Convention.

(c) The President and the Secretary-Treasurer shall, prior to the Convention, prepare an order of business for recommendation to the Convention. See Bylaw I, Sec. 1.02.

(d) The Collegiate and Alumnus Chapters and Association officers may submit nominations for permanent Convention Chair to the Executive Council by June 1 of the Convention year for which the Chair will be selected. After consideration of these nominations, the Executive Council shall appoint a permanent Chair of the Convention in advance of each Convention. The Convention may adopt rules for the conduct of its business and such other matters as may properly come within its jurisdiction. See Bylaw I, Sec. 1.02.

(e) The Convention shall elect the members of the Executive Council as hereinafter provided and fill vacancies for the remainder of the terms of office vacated. See Sec. 6.

(f) The Convention shall consider and vote on all petitions for the establishment of new Collegiate Chapters, the abolishment of Chapters, and matters of discipline presented by the Executive Council. See Const. Art. VI, Sec. 3; Art. IX, Sec. 2; and Bylaw VIII, Sec. 8.04.

(g) The Convention shall levy such assessments upon the Chapters as may be necessary for the support of the Association and the Executive Council.

(h) The Convention shall establish a pro rata assessment on the Collegiate Chapters as specified in the Bylaws for its financial support. See Const. Art. XII and Bylaw I, Sec. 1.05.

(i) The Convention may fix the time and place of the annual Convention not more than three years in advance.

(j) The Convention shall have the power to remove the Secretary-Treasurer of the Association from office for inability to fully and satisfactorily discharge the duties of the office, moral delinquency, incompetence, dereliction of duty, or malfeasance of office. See Const. Art. IV, Sec. 2(c).

(k) The Convention shall be the final Court of Appeal in all questions of interpretation of the Constitution and Bylaws and in all matters of discipline. See Const. Art. IX.

(l) The Convention may enact Bylaws for the Association. The procedure for amendment of the amending procedure of such Bylaws shall follow the same requirements for amending this Constitution as set forth in Article XVIII. See Bylaw XV, Sec. 15.04.

**SECTION 3. Executive Council.** (a) The Executive Council shall consist of five persons who shall be alumnus members. They shall serve without compensation simultaneously

for a period of four years, or until their successors are chosen and qualified. The members of the Council shall be elected by the Convention.

(b) Any Chapter, Collegiate or Alumnus, may nominate a group of five alumnus members to serve as the Executive Council. Such nomination shall be made to the Executive Council before April 1 preceding the Convention at which the election is to be held. Elections shall be held every four years, beginning 1949.

(c) A Chapter making a nomination of a group shall vouch for the willingness of each of its nominees to serve actively on the Executive Council for a term of four years if elected.

(d) The Council shall cause to be published in April to the Chapters, for their consideration, a list of the nominated groups and information concerning each person so nominated.

(e) If a nominee dies or becomes unavailable for election prior to the Convention at which the election is to be held, the nominating Chapter shall present the name of a replacement through the Secretary-Treasurer of the Association to each Chapter delegate prior to the election.

(f) The Convention shall vote only on the published groups, except that if only one group has been nominated, any member of the Convention may nominate a group of five alumnus members to serve as the Executive Council, provided the member is certain that the nominees are willing to serve if elected.

(g) An Executive Council must be elected by the favorable vote of a majority of the qualified voters registered at the Convention. A vote by the Convention will cause the nominated group receiving the least number of ballots to be dropped from further consideration until a group receives a majority vote. The numerical results of each ballot will be made known to the Convention before any subsequent ballots are cast.

(h) The members of the Executive Council shall take office within fourteen months and not earlier than eleven months after their election. The period of eleven-to-fourteen months shall be employed for the outgoing Council to instruct the Council-elect in the duties of the offices. The transfer of responsibility shall take place at a time within the period of eleven and fourteen months after election as shall be mutually agreed upon by the members of the new and old Councils. In the event that a transfer date is not mutually agreed upon, the transfer will occur automatically fourteen months after election.

**SECTION 4. Council Officers.** (a) The Executive Council-elect shall meet at least two months prior to taking office for the purpose of selecting a chair, a vice-chair, and a secretary from the five members of the Council; the selection shall be confirmed by the Council at its first official meeting after taking office and recorded in the official minutes of the Council. The secretary and remaining members of the Council shall be known as Councillors.

(b) The Chair of the Council shall preside at all meetings of the Council. The Vice-Chair shall perform the duties of the Chair in the case of absence of the Chair or the inability of the Chair to act. The Secretary of the Council shall keep accurate minutes of all meetings of the Council and maintain an official minute book with the minutes of each meeting signed by the Chair and the Secretary of the Council. A signed copy of the minutes shall be furnished to and maintained on file by the Secretary-Treasurer of the Association at the headquarters.

(c) If a vacancy occurs in any office of the Executive Council, the Council shall select one of its members to fill the vacancy.

**SECTION 5. Council Responsibilities.** (a) The Executive Council shall assume leadership of the Association. It shall study, or appoint committees for studying, such subjects as from time to time seem desirable. The Council may prepare legislation, amendments, proposals for change, etc., for consideration by the Chapters, or by the Convention, or both. It shall determine the salary of the Secretary-Treasurer and report the amount to the annual Convention. It shall determine the salary of the Assistant Secretary-Treasurer on the recommendation of the Secretary-Treasurer.

C-III, 5 (b)

(b) The Executive Council shall issue, or cause to be issued, Charters, copies of the Constitution and Bylaws, and Rituals to new Chapters.

(c) The Executive Council shall issue, or cause to be issued, a certificate of membership, an official badge, and a copy of the Constitution and Bylaws to each newly-elected member of the Association.

(d) The Executive Council shall receive, disburse, invest, and/or administer, or cause to be received, disbursed, invested, and/or administered, all funds of the Association, both general and special, in accordance with the Constitution and Bylaws, and the Acts of the Convention, and shall administer all gifts, bequests, and endowments in accordance with their provisions.

(e) The Executive Council shall make such investigations for and reports to the Convention as may be directed by the Convention from time to time.

(f) The Executive Council shall call a special Convention upon receipt of a written petition from a majority of the Collegiate Chapters, or it may call a special Convention for a specific purpose upon its own initiative. The time and place for a Convention called for by the Chapters shall be established within one month after receiving the petition, and the meeting shall be held within two months after receiving the petition unless a later time is stipulated in the petition. A notice of such special Convention shall be given by United States first class mail or international equivalent to each Chapter not less than one month in advance of the special Convention.

(g) The Executive Council may change the time and place of the meeting of the annual Convention and may suspend the meeting of the same for a period not to exceed one year, provided that the written consent of two-thirds of the Chapters shall be obtained to any postponement exceeding two months.

(h) The Executive Council shall make an annual report in writing through its Chair to the Convention of its activities during the preceding year. See Bylaw II, Sec. 2.03.

(i) The Executive Council shall appoint all officers of the Association in accordance with the requirements of Article IV of this Constitution.

(j) The Executive Council shall have general supervision of all publications of the Association, including the periodical magazines, THE BENT and THE BULLETIN. See Bylaw IX.

(k) The Executive Council shall determine the number of Districts and the Chapter assignments thereto and set policy for the District Program. See Const. Art. II, Sec. 2.

**SECTION 6. Council Vacancy.** If a vacancy occurs on the Executive Council subsequent to election, and/or subsequent to taking office, the remaining members of the Council shall appoint a qualified member of the Association to fill the vacancy for the unexpired portion of the term or to serve until a successor is duly elected and qualified. The appointment shall be submitted to the next following Convention for confirmation by a simple majority vote.

**SECTION 7. Fiscal Year.** The fiscal year of the Association shall begin on August 1st and end on July 31st.

## **Article IV**

### *Association Officers and Directors*

**SECTION 1. Association Officers and Directors.** The officers of the Association shall be a President, a Vice-President, a Secretary-Treasurer, who shall also be known as the Executive Director of Tau Beta Pi, and an Assistant Secretary-Treasurer. The directors of the Association shall be Councillors, a Director of Rituals, a Director of Fellowships, a Director of Engineering Futures, and District Directors.

**SECTION 2. Designation and Duties.** (a) The President shall be the member of the Executive Council who has been elected by the Council as its Chair and shall be the executive head of the Association.

(b) The Vice-President shall be the member of the Executive Council who has been elected by the Council as its Vice-Chair and shall perform the duties of the President in case of the absence of the President or the inability of the President to act.

(c) The Secretary-Treasurer shall be appointed by the Executive Council on a permanent full-time basis. The Secretary-Treasurer shall be an alumnus member of the Association and shall hold office, unless suspended or removed for just cause as hereinafter provided, until retirement. The Secretary-Treasurer may be suspended by the Executive Council but can be removed from office only by the Convention, in accordance with Article III, Section 2(j), of this Constitution.

(d) The Secretary-Treasurer shall:

- (1) Act as recording and corresponding secretary of the Association;
- (2) Keep or cause to be kept full and complete records of the membership of the Association;
- (3) Keep the official copies of the Constitution and the Bylaws, the seal of the Association, and all the official documents belonging to the Association;
- (4) Serve as the Editor of such publications as may be prescribed by the Executive Council, the Convention, or the Bylaws;
- (5) Serve as the Secretary of the Convention;
- (6) Keep the financial records of the Association;
- (7) Receive and disburse money as authorized by the Executive Council or as prescribed in the Constitution and Bylaws of the Association;
- (8) Make and present a written annual report to the Executive Council and the Convention;
- (9) Perform such duties as may be prescribed in the Constitution and Bylaws of the Association and as directed by the Executive Council. See Bylaw III, Sec. 3.01.

(e) The Assistant Secretary-Treasurer shall be appointed by the Executive Council on a full-time basis on the recommendation of the Secretary-Treasurer. The Assistant Secretary-Treasurer shall be an alumnus member of the Association, shall hold office until retirement unless terminated by the Executive Council, and shall perform such duties as are directed by the Secretary-Treasurer.

(f) Councillors shall perform such duties as required by the Constitution. See Const. Art. III, Sec. 5.

(g) The Director of Rituals, Director of Fellowships, and Director of Engineering Futures shall be appointed by the Executive Council to serve a term of four years beginning on July 1st after the Executive Council takes office. The District Directors shall be appointed by the Executive Council to serve staggered terms of three years beginning July 1st, with approximately one-third of the terms expiring each year. These Directors may be reappointed. They shall be alumnus members of the Association and shall serve without compensation. They may be reimbursed for reasonable expenses and for travel authorized by the Executive Council.

(1) The Director of Rituals shall have custody of and cognizance over the form, phraseology, and physical make-up of the rituals, receive and digest suggestions for changes, and, in general, be responsible for all matters in connection with the rituals and the related ceremonies, subject to approval by the Convention. The Director of Rituals shall keep a master copy of each of the rituals, and provide the Executive Council with five exact copies of each of them. All copies furnished to the Chapters shall be exact duplicates of the master copy. The master copy of each of the rituals shall have the written approval of the Executive Council. See Bylaws I, Sec. 1.07, and III, Sec. 3.03.

(2) The Director of Fellowships shall manage the Fellowship and Scholarship Programs of the Association. The Director of Fellowships shall be a member of and shall chair the Fellowship Board. The Fellowship Board shall consist of three alumnus members in addition to the Director of Fellowships. The Director of Fellowships shall recommend to the Executive Council the appointment of one member to the Board each year for a three-year term, the term of office to commence on August 1st. A Board member may be reappointed. The Board shall review all applications for Tau Beta Pi fellowships and scholarships, and shall select those to whom a fellowship or scholarship shall be awarded in accordance with the number authorized and funds made available by the Executive Council. See Bylaws III, Sec. 3.04, X, and XI.

C-IV, 2(g)(3)

(3) The District Directors shall guide and encourage worthy activities of the District Collegiate and Alumnus Chapters; shall assist alumnus members of Chapter Advisory Boards; shall encourage student-alumnus interaction; shall represent the District alumni at the Convention; shall promote District activity such as meetings, newsletters, and joint chapter initiations and functions; and shall make an annual report in writing to the Executive Council. See Bylaw III, Sec. 3.05.

(4) The Director of Engineering Futures shall manage the Engineering Futures Program of the Association. The Director of Engineering Futures shall guide the selection of the curriculum; shall identify and recommend to the Executive Council the appointment of facilitators to present the curriculum; shall arrange the training and appraisal of facilitators in order to ensure the quality of presentations; shall oversee the requests from the Chapters for presentations and the assignments of facilitators to support these requests; shall coordinate budget requests to the Executive Council and external fundraising efforts; and shall coordinate the development and use of relevant publicity information. The Director of Engineering Futures may appoint subcommittees to assist in these responsibilities, subject to the approval of the Executive Council. See Bylaw III, Sec. 3.06, and Bylaw XIII.

**SECTION 3. Vacancy.** In the event that any office except that of Councillor becomes vacant, the Executive Council shall fill the vacancy as promptly as possible, and in any event within one year of the date on which the office becomes vacant. The responsibilities, duties, and authority of any vacated office shall rest in the Executive Council until such vacancy is filled.

**SECTION 4. Indemnification.** Each member of the Executive Council, each member of the Trust Advisory Committee (See Const. Art. XVII, Sec. 5), and each officer, their heirs, executors, and administrators, shall be indemnified by the Association against the expenses reasonably incurred by such person in connection with any action, suit, or proceeding to which the member may be made a party by reason of serving or having served as a member of the Executive Council or as an Officer of the Association, except in relation to matters as to which the member shall be finally adjudged in such action, suit, or proceeding, to be liable for negligence or misconduct in the performance of duties. Such expenses shall include the cost of reasonable settlement made with a view to curtailment of litigation, reasonable cost of employment of counsel, and the reasonable expense incurred in the preparation and trial of the litigation. The foregoing right of indemnification shall not be exclusive of other rights to which such person may be entitled as a matter of law.

**SECTION 5. Bond.** All officers, directors, and members of the headquarters staff shall be bonded to a proper amount or have equivalent insurance protection at the expense of the Association.

## **Article V**

### *Retirement Provisions*

**SECTION 1. Coverage.** The Executive Council shall establish an insurance and annuity account with Teachers Insurance and Annuity Association (TIAA) for the retirement of the Secretary-Treasurer, the Assistant Secretary-Treasurer, and such other employees of the Association as in its discretion shall be so included.

**SECTION 2. Payments for Secretary-Treasurer and Assistant Secretary-Treasurer.** Upon the completion of three years of full-time employment with the Association, five per cent (5%) of the Secretary-Treasurer's and the Assistant Secretary-Treasurer's salaries shall be retained by the Association and transmitted monthly with equal amounts from the general funds of the Association to their accounts with TIAA.

**SECTION 3. Payments for Other Employees.** The specific contributions for employees other than the Secretary-Treasurer and Assistant Secretary-Treasurer shall be determined by the Executive Council in the event that it is determined that a retirement program shall be established for such employees.

SECTION 4. **Secretary-Treasurers Emeritus.** The Association shall provide for the attendance of the Secretary-Treasurers Emeritus at the Convention.

## Article VI

### *Collegiate Chapters*

SECTION 1. **Chapter Membership.** The active membership of any Collegiate Chapter shall consist of all undergraduate members, either by Chapter initiation or by transfer (see Bylaw VI, Section 6.07), and graduate student members who have indicated in writing their desire to be fully active in Chapter affairs except as stated in Bylaw VI, Section 6.06, and such alumnus members as have expressed in writing to the President of the Chapter their desire either to continue or to assume the responsibilities of active membership and have been formally accepted by the Chapter. An active alumnus member of a Collegiate Chapter shall not have the right of voting on new members and on the amounts of the initiation fee, dues, assessments, and fines. An alumnus member shall cease to be an active member of a Chapter when leaving the college or by resignation.

SECTION 2. **Petition for Chapter.** (a) A preliminary petition for the establishment of a Collegiate Chapter may be made by students and graduates of any regionally accredited college or university who are eligible under Article VIII of the Constitution. This petition shall be addressed to the Executive Council to reach Headquarters prior to June 1 of the calendar year before the Convention would take action on it. The petition shall be made in accordance with the requirements of Bylaw IV, shall set forth the desires of the petitioners, and shall pledge their willingness to subscribe to and obey the Constitution and Bylaws of the Association. The petition shall include a statement of approval for the establishment of a Chapter by appropriate authorities of the institution. The petition shall contain a statement certified by authorities at the institution that each of the petitioners meets the eligibility requirements specified in Article VIII of the Constitution and in the Bylaws of the Association.

(b) The Executive Council shall review the preliminary petition and determine if the institution is qualified for detailed inspection. If the Council determines that the institution is qualified for it, this inspection shall be made in accordance with the Bylaws. If the Council determines that the institution is not qualified for inspection, the petitioners shall be so advised and the reasons therefor given to them, and this action shall be reported to the next Convention. The Convention may sustain the action of the Council, or it may vote to request the Council to proceed with an inspection in accordance with the Bylaws.

(c) The Executive Council shall consider the report and recommendation of the Inspection Committee as prescribed in Bylaw IV, Sec. 4.02. The decisions of the Inspection Committee and the Council will be reported to the Convention following the inspection.

(1) If the Council approves, the petitioners shall submit copies of a formal petition and catalog in accordance with the Bylaws for the Petitions Committee of the Convention. The formal petition will include any required updates or changes to the preliminary petition.

(2) If the Council considers further actions by the petitioners necessary, conditional approval may be given to allow correction of the specified deficiencies prior to June 1 of the year in which the Convention would take action on the petition. The Council would then reconsider its decision and visit the institution if necessary.

(3) If the Council disapproves, the Convention may approve the preliminary petition and request the petitioners to submit a formal petition in accordance with the Bylaws, to be considered by the next Convention.

SECTION 3. **Vote on Chapters.** A Collegiate Chapter shall be established or abolished, and a charter granted or withdrawn, only by at least a three-fourths majority of the total accredited votes of the Convention, taken by written ballot.

**SECTION 4. Installation.** When the establishment of a Chapter is voted by the Convention, the Executive Council shall cause to be prepared an official charter, official roll and record books, and a copy of the Constitution and Bylaws, and shall proceed, in person if feasible or by an appointed deputation if not, to take these documents, to initiate the new members, and to install the petitioners according to the rituals and ceremonies of the Association. The charter shall be carefully preserved by the officers of the Chapter.

**SECTION 5. Control.** Each Chapter shall have full control of its individual affairs, subject to this Constitution and the Bylaws of the Association. A Chapter shall enact Bylaws for its own guidance, and such Bylaws shall not be in conflict with this Constitution or the Bylaws of the Association and shall not be suspended except with the written consent of a majority of the Advisory Board of the Chapter. Internal business of a chapter may be conducted in its local language and currency. See Bylaw V, Sec. 5.03 (d) (6).

**SECTION 6. Officers.** The officers of each Chapter shall be a President, a Vice-President, a Recording Secretary, a Corresponding Secretary, a Treasurer, and a Cataloger, who shall be active members of the Chapter, and four alumnus advisors, all of whom shall be elected by the Chapter. The duties of these officers shall be those usually performed by persons holding such offices, and as the Constitution and Bylaws of the Association and the Bylaws of the Chapter shall prescribe. See Bylaw V.

**SECTION 7. Advisory Board.** (a) The Advisory Board of the Chapter shall consist of the President, the Vice-President, and the Corresponding Secretary of the Chapter, and the four alumnus advisors elected by the Chapter. In first organizing the Advisory Board of any Chapter, the four alumnus members shall be elected to serve for periods of one, two, three, and four years respectively, and thereafter one member shall be elected each spring, to hold office for four years. See Bylaw V, Sec. 5.03 (h).

(b) The Advisory Board shall act as an advisory and judiciary committee to determine the advisability of any action taken or proposed by the Chapter. Such action may be referred to it by a vote of the Chapter or brought before it by a petition of a minority of the same, or the Board may review such action on its own initiative. All changes in the Bylaws of a Chapter must be submitted to, and approved by, the Advisory Board before going into effect. The Advisory Board, by a majority vote, may forbid any such action or change, subject to an appeal to the Executive Council of the Association.

**SECTION 8. Proxy.** A member of a Chapter shall not be allowed to vote by proxy.

**SECTION 9. Meetings.** Each Collegiate Chapter may arrange for and hold such meetings as it desires, but at least one business meeting and one general meeting of a social, literary, or technical character shall be held each term, quarter, or semester, except in the summer, in addition to the meetings held for the consideration, election, and initiation of candidates for membership.

## Article VII

### *Alumnus Chapters*

**SECTION 1. Application and Membership.** (a) An Alumnus Chapter may be chartered by the Executive Council when application is made in writing by at least ten members of the Association and upon payment to the Association of a charter fee as specified in the Bylaws.

(b) An Alumnus Chapter shall be composed of members of Tau Beta Pi who are not undergraduate students and who have signified in writing their desire to become affiliated with an Alumnus Chapter and their willingness to comply with its Bylaws.

(c) The annual dues of an Alumnus Chapter to the Association, as specified in the Bylaws, shall be payable to the Secretary-Treasurer of the Association on the first day of January of each year. See Bylaw III, Sec. 3.01 (e) (14).

**SECTION 2. Officers.** (a) Each Alumnus Chapter shall elect annually a President, a Secretary, and a Treasurer. The offices of Secretary and Treasurer may be combined into one office of Secretary-Treasurer. There shall be an Executive Committee consisting of the officers and such additional members as the Chapter may elect.

(b) The Chapter shall be self-governing, but its actions shall not be in conflict with the Constitution and Bylaws of the Association.

**SECTION 3. Duties.** Members of each Alumnus Chapter shall continue to uphold the principles, esprit de corps, and ideals of The Tau Beta Pi Association, to advance the causes of the engineering profession, and to be of service to local members of the Association and to the membership of neighboring Collegiate Chapters.

**SECTION 4. Convention Representation.** (a) Each Alumnus Chapter may be represented by one or more delegates at the Convention, and if represented, it shall have one vote in the Convention, provided that the Alumnus Chapter has paid its annual dues to the Association. A delegate from an Alumnus Chapter shall represent that Chapter only.

(b) The on-site expenses of the delegate of an active Alumnus Chapter to the Convention shall be paid by the Association to the same extent as the collegiate delegates.

**SECTION 5. District Activities.** An Alumnus Chapter shall cooperate with the Director(s) of the District to which it is assigned and shall participate in the activities of its District to the extent of the capability of its members.

## Article VIII

### *Membership*

**SECTION 1. Election.** (a) There shall be only one class of members, but for convenience, they shall be called Undergraduate Members if they are undergraduate students, Graduate Student Members if they are graduate students, and Alumnus Members if they are no longer in college.

(b) All candidates for membership shall be elected by a Collegiate Chapter. They shall be initiated in a formal ritual ceremony (see Const. Art. I, Sec. 8) either by the Chapter, by another Chapter designated by the Secretary-Treasurer, or by a group of members designated by the Director of Rituals or the Executive Council. See Const. Art VI, Sec. 4; and B. I, Sec. 1.07.

(c) The election of all members shall be by a secret ballot and by a majority of the active Chapter membership eligible to vote thereon. See Bylaw V, Sec. 5.07; and B. VI, Sec. 6.03.

(d) Normally, there shall be two elections and initiations of students held each year, namely, near the beginning of the first and second quarters, terms, or semesters (or, at the option of the Chapter, the first and third quarters) of the college year. See B. VI, Sec. 6.01 (a).

(e) On recommendation of the Advisory Board, the Executive Council may authorize special elections or initiations other than those just specified. See Bylaw VI, Sec. 6.01 (b).

**SECTION 2. Eligibility of Undergraduate Students.** (a) To be eligible for election, the candidate shall be a student pursuing an undergraduate engineering curriculum of the institution. An engineering curriculum is defined as one that meets any of the following criteria: (i) is accredited by the Engineering Accreditation Commission of the Accreditation Board for Engineering and Technology (EAC/ABET) or its engineering-accreditation successor(s); (ii) is administered by a unit (a department, school, or college) of engineering and has the same name as any program accredited as described in criterion (i); or (iii) is administered by a unit of engineering and includes the noun 'engineering' in its name.

C-VIII, 2 (a)

Candidates for membership shall meet the scholarship provisions of this Constitution and shall have exemplary character as enunciated in the Eligibility Code of the Association.

(b) A Chapter may appeal to Convention the eligibility of students of other undergraduate curricula that: (i) are administered by a unit of engineering of the institution; (ii) have received the three-fourths favorable vote of the active Chapter membership eligible to vote thereon (see Const. Art. VI, Sec. 1); and (iii) have received the five-sevenths favorable vote of the Advisory Board of the Chapter. Such curricula that have received the approval of Convention shall be considered engineering curricula as well.

(c) A Chapter may decide for itself by a three-fourths majority vote, subject to the five-sevenths approval of its Advisory Board, to exclude from eligibility all students of a particular undergraduate curriculum that, in the opinion of the Chapter, is not an engineering curriculum. Curricula satisfying criterion (i) of Const. Art. VIII, Sec. 2(a) may not be excluded.

(d) A Chapter must list in the Bylaws of the Chapter all curricula that it deems worthy to qualify a candidate for eligibility. See Bylaw V, Sec. 5.03.

(e) Juniors who are scholastically in the upper eighth of all juniors of curricula listed in the Chapter's Bylaws per Subsection (d) shall be eligible for election.

(f) To be considered juniors, students shall be in the next-to-the-last year of their curriculum or shall have completed the institution's requirements for junior standing. In institutions with a cooperative program, students may be regarded as juniors when fifty percent of the institution's specified undergraduate academic degree requirements have been completed.

(g) Seniors who are scholastically in the upper fifth of all seniors of curricula listed in the Chapter's Bylaws per Subsection (d) shall be eligible for election.

(h) To be considered seniors, students shall be in the last year of their curriculum or shall have completed the institution's requirements for senior standing. In institutions with a cooperative program, students may be regarded as seniors after having completed seventy-five percent of the undergraduate academic degree requirements specified by the institution.

(i) The upper eighth and fifth of a class shall be determined by the relative point ratings (except as noted below) based upon the net number of regular engineering students enrolled in the junior and senior classes respectively at the time of election. See Bylaw VI, Sec. 6.02. If a Chapter is unable to obtain the relative point ratings or fulfill the requirements of Bylaw VI, Section 6.02 and/or Section 6.04, the Chapter shall submit in writing the method used for determining the upper eighth and fifth to the Executive Council for approval or disapproval.

(j) Special students and those students who are not candidates for an engineering degree shall not be counted, and transfer students who are not eligible for election need not be counted, in determining the enrollment or the numbers who are eligible for election.

(k) Undergraduate students transferring from another institution shall not be eligible for election until the third regular election after their registration. Students subject to this subsection shall be eligible at the second regular election after their registration, provided the consent of five-sevenths of the Advisory Board is obtained and they meet the other requirements for election. See Bylaw VI, Sec. 6.02 (d).

(l) The cases of students whose eligibility is in doubt because of irregular standing or curriculum shall be referred to the Advisory Board of the Chapter and to the Executive Council for the determination of the terms and times of eligibility.

(m) The existence of conditions or failures in a student's undergraduate record shall not prevent consideration and election, provided the point-rating is within the upper eighth or fifth of the class.

**SECTION 3. Eligibility of Graduate Students.** (a) A Chapter may elect to membership any candidate in a graduate engineering curriculum (see Section 2(a) for the definition of an engineering curriculum) at its institution after the student has been in residence for one semester or two quarters and has completed at least 50% of the degree requirements, including coursework and research, as determined by the student's primary academic advisor.

(b) A Chapter may appeal to Convention the eligibility of students of other graduate curricula that: (i) are administered by a unit of engineering of the institution; (ii) have received the three-fourths favorable vote of the active Chapter membership eligible to vote thereon (see Const. Art. VI, Sec. 1); and (iii) have received the five-sevenths favorable vote of the Advisory Board of the Chapter.

(c) A Chapter may decide for itself by a three-fourths majority vote, subject to the five-sevenths approval of its Advisory Board, to exclude from eligibility all students of a particular graduate curriculum that, in the opinion of the Chapter, is not an engineering curriculum. Curricula satisfying criterion (i) of Section 2(a) may not be excluded.

(d) A Chapter must list in its Bylaws all graduate engineering curricula that it deems worthy to qualify a candidate for eligibility. See Bylaw V, Sec. 5.03.

(e) Complete proof of the worthiness of a candidate for election shall be presented in writing to the Secretary-Treasurer of the Association. Such proof shall include: (i) evidence of the candidate's scholastic eligibility, consisting of certification of the standing in the top fifth of the graduate class. If, and only if, class rank cannot be determined, a statement by a faculty member that the candidate is doing graduate work of the quality expected of a member of the Association shall be substituted for class-rank certification; (ii) a list of the degree(s) held by the candidate, the institution(s) which granted the degree(s), and the year in which each degree was granted; and (iii) a statement from the Advisory Board of the Chapter that it believes the candidate to be worthy of membership in the Association and approves election of the student. See Bylaws VI, Sec. 6.04 (a) and (b); and VIII, Sec. 8.04.

**SECTION 4. Eligibility of Alumni of Own Institution.** (a) A Chapter may elect to membership any alumnus of its institution who:

(1) Graduated before the establishment of the Chapter at that institution and who would have been eligible for membership had the Chapter existed prior to the graduation of the alumnus.

(2) Was eligible as an undergraduate or graduate student but was overlooked rather than considered and rejected, or was eligible under the provisions of Section 2 or 3 but was not considered because of the scholastic rules of the Chapter at that time.

(3) Was elected while an undergraduate or graduate student but refused membership at that time for financial or other reasons (see Section 10).

(4) Was considered eligible as an undergraduate or graduate student at the last election held before graduation but was rejected for reasons judged proper by the Chapter at that time. A candidate may be elected under this subsection only by a seven-eighths favorable vote of the active membership of the Chapter.

(5) Was not eligible at the times of election as an undergraduate, but who was graduated in the upper fifth of the undergraduate class.

(b) All elections under this section shall comply with the applicable provisions of Section 7.

**SECTION 5. Eligibility of Alumni of Other Institutions.** (a) A Chapter may elect to membership any alumnus of a recognized engineering college other than the one in which the Chapter proposing to elect is located who:

(1) Graduated when a Chapter did not exist at the person's alma mater and who would have been eligible had a chapter existed.

(2) Was eligible as an undergraduate or graduate student but was overlooked, rather than considered and rejected, by the Chapter at the alma mater, or was eligible under the provisions of Section 2 or 3 but was not considered because of the scholastic rules of the Chapter at the alma mater at that time. Elections under this subsection shall comply with the provisions of Subsection (b).

(3) Was elected while an undergraduate or graduate student, but who refused membership at that time for financial or other reasons. Elections under this subsection shall comply with the provisions of Subsection (b).

(4) Was considered eligible as an undergraduate or graduate student at the last election held before graduation but was rejected for reasons judged proper by the Chapter at the alma mater at that time. A candidate may be elected under this subsection only by a seven-eighths favorable vote of the active membership of the Chapter considering the candidate. Elections under this subsection shall comply with the provisions of Subsection (b).

(5) Was not eligible at the times of election as an undergraduate but was graduated in the upper fifth of the undergraduate class. Elections under this subsection shall comply with the provisions of Subsection (b).

(b) The Chapter desiring to elect a candidate under Subsection (2), (3), (4), or (5) must secure from the Chapter of the candidate's alma mater a letter of release which shall state that, upon investigation, the latter Chapter can find no objection to the proposed election and waives its right to nominate and elect the candidate as a member of its own Chapter. If the Chapter at the candidate's alma mater (1) desires to elect the candidate as one of its own alumnus members, it shall have that privilege, provided it agrees to consider and vote on the candidate at its next regular election; (2) objects to the proposed election, it shall so inform the Chapter desiring to elect the candidate and the Secretary-Treasurer of the Association, and the candidate shall not be eligible for membership; (3) fails to reply within three weeks, the Chapter proposing to elect the candidate may appeal to the Executive Council for a decision on the merits of the case.

(c) All elections under this section shall comply with the applicable provisions of Section 7.

**SECTION 6. Eligibility of Eminent Engineers.** (a) A Chapter may elect to membership any alumnus of a recognized engineering college who graduated more than ten years ago and who has achieved distinction for eminent attainments in engineering.

(b) A Chapter may elect to membership an engineer who is not a graduate of a recognized engineering college, who has had fifteen years of experience in the practice of engineering, and who has achieved distinction for eminent attainments in engineering.

(c) All elections under this section shall comply with the applicable provisions of Section 7.

**SECTION 7. Eligibility Requirements for Alumni and Eminent Engineers.** (a) To be eligible for election to membership under Sections 4, 5, or 6, a candidate must be a person of character, ability, and integrity; must have a continuous record of intellectual activity and of attainment in engineering; must be a person such as an undergraduate member of Tau Beta Pi might be expected to become; and shall be one who should be expected to add credit and honor to the Association. The qualifications with regard to attainment in engineering need

not be required of candidates who are otherwise eligible under Section 4(a)(1) or 5(a)(1).

(b) Teaching of professional engineering subjects shall be considered as professional engineering experience. Administrators with engineering training and experience whose duties include supervision of professional engineering work shall be considered as being engaged in the engineering profession.

(c) Complete proofs of the worthiness of the candidate, scholastic eligibility, and professional engineering record where required, the desirability of bestowing membership, and the approval of the Advisory Board of the Chapter which has elected the candidate must be presented in writing through the office of the Secretary-Treasurer of the Association to the Executive Council for its approval. The candidate's election shall not be completed and valid until approval of the election by the Executive Council has been received by the nominating Chapter. See Bylaws VI, Sec. 6.04(a) and (b); and VIII, Sec. 8.04.

(d) At the establishment of a new Chapter, neither an alumnus of the institution nor any other engineer shall be initiated unless the requirements of this section and of Section 4, 5, or 6 shall have been complied with in all details for each candidate by the petitioning group acting as a Chapter.

**SECTION 8. Other Memberships.** Membership in any other society, fraternity, or association shall not of itself bar a candidate from election to Tau Beta Pi.

**SECTION 9. Resignation.** A member shall be allowed to resign from The Tau Beta Pi Association providing all insignia of the Association are forfeited and provided no disciplinary action is pending against the member. No refund will be made.

**SECTION 10. Financial Inability.** (a) Whenever a student pleads financial inability to accept membership, the Advisory Board of the Chapter shall be notified of the fact. In cases where an Advisory Board interview establishes that a refusal is solely for financial reasons, the facts shall be certified to the Secretary-Treasurer of the Association. Such a candidate may be initiated at any time within five years of election upon review of the case by the Chapter, and if found to be still worthy, the Chapter shall offer to initiate the electee. If after review the electee is rejected, reasons for the rejection shall be filed with the Secretary-Treasurer of the Association.

(b) If an electee who has refused membership because of financial inability has not been reviewed by the Chapter by the end of five years following election, the Chapter shall be so notified by the Secretary-Treasurer of the Association, the case reviewed, and the electee subsequently initiated or rejected. The Secretary-Treasurer of the Association shall be notified of the action taken.

**SECTION 11. Initiation by Error.** If an ineligible person is initiated by error or mistake, the Executive Council may cancel the membership and recall the official badge and certificate of that person upon the recommendation of a majority of the active members of the Chapter and of its Advisory Board. The Executive Council shall report to the next Convention its action and reasons therefor in such cases. A member may appeal the decision of the Executive Council to the next regular Convention of the Association, and the member shall have the right to be heard by the Convention and to plead the member's own case. The

## Article IX

### *Discipline*

SECTION 1. **Methods for Chapters.** A Chapter may be disciplined by probation or by annulment of its Charter.

SECTION 2. **Procedures for Chapters.** (a) Any Chapter that:

(1) is reported in writing to the Executive Council or to the Convention by twenty-five alumnus members of the Association or by three other Chapters as having acted in a manner contrary to the Constitution or prejudicial to the interests of the Association,

(2) conducts more than one unapproved initiation (see Bylaws VI, Sec. 6.04 and VIII, Sec. 8.02) in a period of two consecutive fiscal years, or

(3) fails to hold at least one approved initiation during a fiscal year shall be automatically placed on probation, subject to appeal to the Executive Council.

(b) The Chapter's probation may be continued or its charter may be annulled or restored to the Chapter by action of the Convention by a three-fourths vote, taken by roll-call, of those present and entitled to vote. In the event of continued probation, the Chapter shall be called at the next Convention to show reason why its charter should not be annulled, and the Convention shall either annul the charter of the Chapter or restore the charter to the Chapter with full rights and privileges.

(c) Probation of a Chapter shall entail: Such penalties as are deemed appropriate by the Executive Council or the Convention; and Continuation of Chapter activities in support of the objectives of the Association.

SECTION 3. **Fines on Chapters.** A uniform system of fines shall be established, and these fines shall be assessed against, and paid by, every Chapter guilty of inexcusable acts of lateness or neglect to make reports to the Secretary-Treasurer of the Association, as prescribed by the Constitution and Bylaws. See Bylaw VIII.

SECTION 4. **Methods for Members.** A member may be disciplined by suspension or expulsion.

SECTION 5. **Procedures for Members.** (a) Any member who is reported in writing to the Executive Council upon majority vote of the active members of the Chapter and of its Advisory Board as having continued and inexcusable absence from the meetings of the Chapter, as not attending to assigned or elected duties to the Chapter, as being morally delinquent, as inexcusably failing to meet financial obligations to the Chapter, or for other just cause after a fair trial, may be suspended or expelled by the Executive Council and the member's official badge and certificate recalled. The Executive Council shall report its action and reasons therefor to the next Convention.

(b) Suspension shall entail the following: (1) return of badge and certificate; (2) loss of voting privileges; (3) provision by the Chapter of opportunity for the individual to demonstrate desire to be reinstated.

(c) A member shall be suspended for a specified length of time not to exceed one year. At the end of the time specified the Chapter, with the concurrence of its Advisory Board, shall make recommendation with reasons to the Executive Council in writing either to reinstate or to expel the member. If, as, and when a member is reinstated, the official badge and certificate shall be returned to the member.

(d) A member who is suspended or expelled by the Executive Council may appeal the case to the next regular Convention of the Association, and that member shall have the right to be heard by the Convention and to plead the member's own cause. The Convention shall affirm or modify the action of the Executive Council and its action shall be final.

## Article X

### *BENT Life Subscription Fund*

SECTION 1. **Basis and Use.** The Association shall maintain a Fund to be known as the BENT Life Subscription Fund, the principal of which shall be composed of moneys paid to the Association for Life Subscriptions to THE BENT (official publication of the Association). The income from the investment of this Fund shall be used by the Association in the publication of THE BENT. Upon the death of a Life Subscriber, the amount paid on that subscription shall be transferred on the financial records of the Association by the Secretary-Treasurer to the Fellowship Fund. See Bylaw IX, Sec. 9.05.

SECTION 2. **Administration.** The Life Subscription Fund shall be administered by the trustee in accordance with Article XVII of this Constitution.

## Article XI

### *Fellowship Fund*

SECTION 1. **Basis and Use.** The Association shall maintain a Fund to be known as the Tau Beta Pi Fellowship Fund, the principal of which shall be composed of moneys transferred from the BENT Life Subscription Fund upon the deaths of Life Subscribers, and such other funds as the Executive Council may direct. The income from this Fund shall be used for Fellowship stipends in accordance with the direction of the Executive Council. See Bylaw X.

SECTION 2. **Administration.** The Fellowship Fund shall be administered by the trustee in accordance with Article XVII of this Constitution.

## Article XII

### *Convention Fund*

SECTION 1. **Basis and Use.** The Association shall maintain a Fund to be known as the Tau Beta Pi Convention Fund, the principal of which shall be composed of moneys transferred to it by the Executive Council. The income from the investment of this Fund shall be used to provide financial support for the Convention of the Association.

SECTION 2. **Administration.** The Convention Fund shall be administered by the trustee in accordance with Article XVII of this Constitution.

## Article XIII

### *Student Loan Fund*

SECTION 1. **Source and Purpose.** The Association shall make loans available to any undergraduate or graduate-student member of the Association from prepaid subscriptions to THE BENT (official publication of the Association) in amounts as specified in the Bylaws for any one member. A total amount of not more than one-half of the full-year, prepaid subscriptions to THE BENT shall be on loan to students at one time. A portion of this amount, as specified in the Bylaws, shall be set aside to maintain a Fund, known as the Initiation Fee Loan Fund. This Fund will provide loans to cover initiation fees for new members as needed. The borrowing member shall certify that the loan is needed to help complete work toward a degree, and this certification shall be attested to by the officers of the Chapter and the head of the student's department. The procedure for the administration of the loan funds shall be prescribed in the Bylaws of the Association. See Bylaw XIII.

**SECTION 2. Rate of Interest and Disposition.** The Executive Council shall determine the rate of interest to be charged and other necessary regulations and shall approve of applications through the President. The Executive Council may receive gifts or bequests specifically for loans to members of the Association. One-half of any interest collected from loans shall be placed in the Student Loan Fund for use as loans. The other half of interest collected shall be used to offset any losses incurred, or if no losses are outstanding which cannot be collected, it shall be credited to operating income of the Association to offset expenses of administration.

### **Article XIV**

#### *Contingency Fund*

**SECTION 1. Purpose and Amount.** The Association shall maintain a Fund to be known as the Contingency Fund. The purpose of the Contingency Fund is to provide for unanticipated expenses of the Association and to maintain a proper operating level of the Association in periods of major income reduction. The amount of the Fund shall be established by the Executive Council and may be changed from time to time in the Council's judgment.

**SECTION 2. Management.** The management of the Contingency Fund shall be under the jurisdiction of the Secretary-Treasurer of the Association. Additions to and withdrawals from the Fund shall be made only at the direction of the Executive Council. The income from the investment of this Fund shall be added to the principal of the Fund unless otherwise directed by the Executive Council.

**SECTION 3. Investment.** To assure liquidity, the assets of the Contingency Fund shall be invested in mutual funds, the Tau Beta Pi Trust Fund, and/or securities of the United States Government.

### **Article XV**

#### *Engineering Futures Fund*

**SECTION 1. Basis and use.** The Association shall maintain a Fund to be known as the Tau Beta Pi Engineering Futures Fund, the principal of which shall be composed of moneys transferred to it by the Executive Council. The income from the investment of this fund shall be used to provide financial support for the Engineering Futures Program in accordance with the direction of the Executive Council. See Bylaw XIV.

**SECTION 2. Administration.** The Engineering Futures Fund shall be administered by the trustee in accordance with Article XVII of this Constitution.

### **Article XVI**

#### *Scholarship Fund*

**SECTION 1. Basis and Use.** The Association shall maintain a Fund to be known as the Tau Beta Pi Scholarship Fund, the principal of which shall be composed of moneys transferred to it by the Executive Council. The income from this Fund shall be used for Scholarship stipends in accordance with the direction of the Executive Council. See Bylaw XI.

**SECTION 2. Administration.** The Scholarship Fund shall be administered by the trustee in accordance with Article XVII of this Constitution.

### **Article XVII**

#### *Investment Requirements*

**SECTION 1. Specific Funds.** The custody, responsibility, and accountability for the assets of the BENT Life Subscription Fund, Fellowship Fund, Convention Fund, Engineering Futures Fund, and Scholarship Fund shall rest with a corporate trustee. See Const. Arts. X, XI, XII, XV, and XVI. The Executive Council may place other funds of the Association, except those specifically assigned to other management (see Const. Arts. XIII and XIV), in the hands of the corporate trustee. Funds administered by the trustee may be mingled.

**SECTION 2. Trustee.** The trustee shall be an incorporated bank or a trust company, authorized by the laws of any state in the United States of America to engage in the business of acting as a trustee of private trusts. Such trustee shall be selected, and from time to time may be replaced by another such trustee, in the joint discretion of the Executive Council and of the Trust Advisory Committee hereinafter described.

The trust agreement under which the trustee holds funds of the Association shall be subject to the joint approval of the Executive Council and the Trust Advisory Committee, shall expressly provide that it is subject to the Constitution of the Association, and may be terminated or amended by amendments to the Constitution. The trust agreement may be amended by concurrence of the Executive Council and the Trust Advisory Committee.

**SECTION 3. Trustee Responsibilities.** The trustee shall have the responsibility for investing and reinvesting all assets placed under its jurisdiction in accordance with Section 1 of this Article to meet the objective of the funds, subject in its investment actions to the written approval and direction of the Trust Advisory Committee.

The trustee shall review and either concur with or challenge any investment decision or action of the Trust Advisory Committee (see Sec. 6 below). The trustee shall make reports to each member of the Trust Advisory Committee at least quarterly, and to the Executive Council and the Secretary-Treasurer at least annually. The Secretary-Treasurer shall report to the Convention concerning the financial management of the trustee. Should the report be unfavorable, the Convention may take action.

**SECTION 4. Investment Objectives.** The investment objectives shall be as follows:

- (a) To earn the maximum current rate of return on investments consistent with (b) and (c) below.
- (b) To safeguard the principal of any fund of the Association.
- (c) To take into account important long-range economic influences, such as inflation or deflation, in order to preserve the long-range earning and purchasing power of all funds of the Association.

**SECTION 5. Trust Advisory Committee.** The Trust Advisory Committee shall consist of three members of the Association appointed by the Executive Council. A member of the Trust Advisory Committee shall not be at the same time a member of the Executive Council or hold any other office in the Association. The term of office of the members of the Trust Advisory Committee shall be six years, except as hereinafter provided. Such terms shall be staggered so that every two years one such term shall expire on June 30. The terms of the first members of the Trust Advisory Committee shall be two, four, and six years; the individuals to fill each of the terms shall be determined by lot at the time of appointment. Those appointed to the Trust Advisory Committee by the Executive Council shall be members with outstanding business competency and judgment. The senior member of the Trust Advisory Committee shall be the chair unless the Executive Council appoints another member of the Committee as chair. Decisions of the Trust Advisory Committee shall require the concurrence of at least two of its members.

**SECTION 6. Nonconcurrence.** In the event the trustee does not concur in an investment decision or action of the Trust Advisory Committee, the matter shall be presented to the Executive Council. The decision of the Executive Council shall prevail, and the trustee shall be required to follow any decision.

**SECTION 7. Guiding Rule.** The trustee and the Trust Advisory Committee shall invest the funds by purchasing some combination of:

C-XVII, 7 (a)

- (a) Shares of fixed income and equity mutual funds,
- (b) Preferred and common stocks,
- (c) Money market funds,
- (d) Corporate bonds and debentures,
- (e) Certificates of deposit, and
- (f) Direct obligations of the United States Treasury and of legal agencies of the United States Government.

SECTION 8. **Review Committee.** During the fiscal year 1993-94, and every five years thereafter, the Executive Council shall appoint a Review Committee for the purpose of considering the over-all trust administration and investment policy of the Association. The committee will present its findings and recommendations to the Executive Council in a written report.

SECTION 9. **Investments by Officers.** Funds of the Association that are within the investment jurisdiction of officers of the Association, not including the trustee, and that are not otherwise provided for in this Constitution or in the Bylaws, may be invested only in securities of the United States Government or in banks insured by the Federal Deposit Insurance Corporation, in amounts not to exceed the insured limits.

## Article XVIII

### *Amendments*

SECTION 1. **Proposal.** Amendments to the Constitution shall be proposed by:

- (a) Any Chapter or the Executive Council or the Committee on Constitution and Bylaws at a regular Convention, or
- (b) The Executive Council upon publication to all Collegiate Chapters of the Association.

SECTION 2. **Adoption.** (a) Any amendment proposed in the manner specified in Section 1 (a) of this Article may be adopted by the approval of at least three-fourths of those present and entitled to vote at a regular Convention, and ratification by at least three-fourths of the Chapters by at least a three-fourths favorable vote of the active membership present and entitled to vote at that Chapter meeting, or

(b) Any amendment proposed in the manner specified in Section 1(b) of this Article may be adopted by the approval of at least three-fourths of the Chapters by at least a three-fourths favorable vote of the total active membership of each Chapter.

SECTION 3. **Time Limit of Chapter Vote.** (a) For any amendment proposed in the manner specified in Section 1 (a) of this Article, each Chapter must report its action, or vote, to the Secretary-Treasurer of the Association by the following April 1.

(b) For any amendment proposed in the manner specified in Section 1(b) of this Article, each Chapter must report its action, or vote, to the Secretary-Treasurer of the Association by the date specified in the proposal as determined by the Executive Council, which shall be no less than four months from the date of publication. Failure to provide the report as specified in Sections 3(a) and 3(b) shall be construed as giving the Executive Council the authority to act and vote for that Chapter as the Council may believe to be in the best interests of the Association.

SECTION 4. **Report.** Amendments to the Constitution shall be reported by the Secretary-Treasurer of the Association to each Collegiate and Alumnus Chapter, shall be printed in the official publications of the Association, and shall become the law of the Association.

## **Article XIX**

### *Enactment*

This Constitution, being a revision of the Constitution adopted by the Convention of 1947, and enacted on December 1, 1947, by ratification of the Chapters, was proposed by the Executive Council, with the advice of the Convention of 1965 and of the Chapters, and was enacted on June 6, 1966, by ratification of the Chapters, and thus became the law of the Association.

## **Article XX**

(Ratified December 27, 1973)

### *Merger of Sigma Tau into the Association*

Solely for the purpose of consummating the merger of the Sigma Tau Fraternity and the Sigma Tau Foundation, Inc., into the Association, this Article constitutes a waiver where necessary of applicable provisions of this Constitution and of the Bylaws of the Association in the following regards:

(a) Sigma Tau Chapters at schools without Tau Beta Pi Chapters will, upon approval of school authorities, be converted into Tau Beta Pi Chapters.

(b) All active members and faculty advisors of Sigma Tau Chapters at the time the merger becomes effective, who are not already members of Tau Beta Pi, will be initiated into Tau Beta Pi. Their national initiation charge will be paid from funds made available to the Association from assets of the Sigma Tau Fraternity.

(c) Alumnus members of Sigma Tau may become members of Tau Beta Pi by paying to the headquarters office of the Association the standard national initiation charge, participating in an initiation process determined by the Executive Council, and receiving the materials provided to new members.

THE BYLAWS  
OF  
THE TAU BETA PI ASSOCIATION

**Bylaw I**

*The Convention*

SECTION 1.01. **Assembly.** The Convention, being duly assembled in accordance with the Constitution, shall be called to order by the President of the Association, or in the absence of the President, by the Vice President or other member of the Executive Council, or, if there are none present, by the delegate from the oldest Chapter represented. The Secretary-Treasurer of the Association shall serve as the Secretary of the Convention, shall examine the credentials of the delegates, and shall certify to the Convention the number of Chapters properly represented and the number of officers present. The Secretary-Treasurer shall determine and report if a quorum is present.

SECTION 1.02. **Order of Business.** The first order of business shall be the reading of the President's report of the activities of the Executive Council and reports by other officers of the Association. These reports shall be followed by the recommendation of the President and the Secretary-Treasurer on the order of business for the Convention, after which the Convention shall adopt an order of business. See Const. Art. III, Secs. 2(c) and 5(h); and Art. IV, Sec. 2(d)(2).

The permanent Chair of the Convention, appointed by the Executive Council, shall then assume the Chair. The Chair shall be an alumnus member of the Association. See Const. Art. III, Sec. 2(d).

SECTION 1.03. **Minutes of the Convention.** The Secretary-Treasurer of the Association shall take full and complete minutes of the actions of the Convention and shall, within two months of the conclusion of the Convention, prepare official copies of the minutes and distribute them to all officers of the Association and to all Collegiate and Alumnus Chapters. A copy of the minutes shall be signed by the Chair of the Convention and the Secretary-Treasurer and bound in the permanent book of the Association Conventions for safekeeping by the Secretary-Treasurer of the Association.

SECTION 1.04. **Delegates.** Each Collegiate Chapter shall send one active member as its official delegate to the annual Convention. Collegiate Chapters failing to send a delegate shall be assessed in accordance with Section 1.05. A Chapter or a delegate shall not be allowed to vote by proxy. See Const. Art. III, Sec. 2(a).

SECTION 1.05. **Assessments.** Each Collegiate Chapter shall be assessed an amount, determined by the Convention not to exceed seven dollars (\$7.00), on recommendation of the Executive Council, for each new initiate. This assessment shall be levied automatically on the day of initiation and shall be paid within two weeks after initiation. It shall be charged to the Chapter accounts by the Secretary-Treasurer of the Association. The Secretary-Treasurer shall make available for Convention expenses advance funds from the Association for each Collegiate Chapter. The Secretary-Treasurer shall inform each Collegiate Chapter of the availability of these advance funds in appropriate annual Convention communications. Upon receipt of the delegate's Convention expense report, the Chapter account shall be credited with the approved Convention expenses.

SECTION 1.06. **Delegates' Expense Reports.** The Secretary-Treasurer shall provide forms on which: (a) Each Collegiate Chapter official delegate shall report expenses connected

with the Convention. Allowable expenses of each delegate shall be the actual expenses incurred but shall not exceed:

(1) Coach class travel by air, rail, or bus, when such class is reasonably available, except that for overnight rail, Pullman may be used;

(2) Automobile travel including tolls and parking expenses at the Convention site at a rate approved by the immediate prior Convention;

(3) Expenses at the Convention as approved by the immediate prior Convention, to include housing and meals for a period of time not to exceed twelve hours in advance of the credentials validation deadline, extending through the days of the Convention, and ending not more than twelve hours after the adjournment of the Convention;

(4) Expenses for lodging as approved by the immediate prior Convention for a maximum of one stopover each way to and from the Convention when traveling by automobile in excess of 500 miles (800 km) each way;

(5) Expenses for meals incurred in travel to and from the Convention as approved by the immediate prior Convention; and

(6) Cost of regular franchise airport transportation and other terminal expenses from and to place of residence and between airport and Convention headquarters.

(7) Requests for reimbursement to Chapter delegates for unusual expenses must be submitted to the Executive Council or the Chapter and Association Financial Affairs Committee of the Convention for approval, such approval being obtained prior to the Convention when possible.

(b) Each Alumnus Chapter official delegate shall report on-site expenses connected with the Convention. See Const. Art. VII, Sec. 4 (b).

Receipts are required for reimbursement of expenses with the exception of mileage and tolls.

**SECTION 1.07. Model Initiation.** The Director of Rituals shall designate a group of members to conduct an initiation with due formality and elegance for the instruction of the delegates at the Convention. See Bylaw III, Sec. 3.03.

**SECTION 1.08. Privilege of Member.** Any member of the Association shall be granted the privilege of the floor at a meeting of the Convention.

**SECTION 1.09. Suspension of Bylaws.** The Convention may suspend the Bylaws for a specified purpose by at least a three-fourths majority vote.

**SECTION 1.10. Rules of Order.** Meetings of the Convention shall be conducted in accordance with Robert's "Rules of Order" Revised, subject to the provisions of the Constitution and Bylaws of the Association.

## **Bylaw II**

### *The Executive Council*

**SECTION 2.01. Meetings.** The Executive Council shall hold at least four meetings per year, and the Secretary of the Council shall keep accurate minutes that shall be signed by the Chair and the Secretary. An original of the minutes shall be bound into the official Council Minute Book. A copy of the minutes shall be placed on file with the Secretary-Treasurer of the Association.

**SECTION 2.02. Chapter Actions on Communications.** Communications from the Executive Council to the Collegiate Chapters shall be acted upon by the Chapters within

## B-II, 2.02

one month, not counting regular college vacations, from the time of their receipt. Each Chapter must report its action, or vote, on a communication from the Executive Council to the Secretary-Treasurer of the Association in accord with Constitution Article XVIII, Section 3, or it will forfeit its vote to the Executive Council. See Const. Art. XVIII, Sec. 3.

**SECTION 2.03. Report to Convention.** The Executive Council shall make to each annual Convention a report containing the following items:

- (a) A statement of the condition of the Association, both general and financial.
- (b) The transactions of the Executive Council since the last Convention.
- (c) All recommendations which it deems to be for the good of the Association.
- (d) All subjects brought to its attention by any Chapter.
- (e) All subjects referred to the Council for study or action by the Convention.
- (f) All Chapters and members subject to disciplinary action.
- (g) All petitions for charters.
- (h) Recommendations, if any, for the annulment of Chapters and withdrawal of charters.

## Bylaw III

### *Association Officers*

**SECTION 3.01. Secretary-Treasurer.** The Secretary-Treasurer of the Association shall:

(a) Serve as the Editor of all publications of the Association, and be responsible for the preparation and distribution of such publications. See Bylaw IX.

(b) Periodically recommend to the Executive Council appropriate adjustments in the salary of the Assistant Secretary-Treasurer.

(c) Be empowered to employ such individuals as may be necessary to assist in the conduct of the office, subject to review by the Executive Council as to number and salary.

(d) Issue charters, both temporary and permanent, official copies of the Constitution and Bylaws and of the Rituals to new Chapters, and badges and certificates of membership for all new members and duplicates as required.

(e) Be responsible for:

(1) Sending to the President of each Chapter when it is installed, with the compliments of the Association, a set of the properties, except caps and gowns, commonly used in the initiation ceremonies, for its permanent use. The Chapter shall keep these properties in good condition.

(2) Sending to the Recording Secretary of each Chapter, and charging to the Chapter, when it is installed, a copy of the official loose-leaf record book for the use of the Chapter and sending to each Chapter, when it is installed, a copy of the official Roll Book for the use of the Chapter.

(3) Sending to the Cataloger of each Chapter, when it is installed, a package of one hundred 5 by 3 inch (12.7 cm by 7.6 cm) card catalog cards for the use of the Chapter.

(4) Obtaining from the Corresponding Secretary of each Chapter in October the names and post office addresses of the officers of the Chapter, and subsequently all changes in their memberships which may occur during the year. See Bylaw V, Sec. 5.03(d) (1).

(5) Obtaining from the Corresponding Secretary of each Chapter changes in the post office addresses and/or membership of the Advisory Board as they may occur during the year.

(6) Obtaining from the Corresponding Secretary of each Chapter, in connection with its election and initiation of new members, a Report of Eligibility, Report of Election, Catalog Cards, and Report of Final Action, as required by Bylaw V.

(7) Promptly sending to the Chapter a badge and certificate of membership for each electee.

(8) Obtaining from the Corresponding Secretary of each Chapter items of news interest and items concerning disciplines, as required by Bylaw V.

(9) Obtaining from each Chapter a copy of the Chapter's Bylaws, amended to date, with the written approval of the Advisory Board, as required in Bylaw V.

(10) Sending to the Treasurer of each Chapter when it is installed a copy of the official bookkeeping system of the Association with instructions as to its use. See Bylaw V, Sec. 5.03(e)(2).

(11) Sending monthly during the college year to the Treasurer of each Chapter a statement showing the financial condition of its account with the Association.

(12) Levying the Convention assessments against the Chapters on the day of initiation. See Bylaw I, Sec. 1.05.

(13) Obtaining a payment to the Association of an Alumnus Chapter charter fee of \$10.

(14) Collecting the \$5 annual dues of the Alumnus Chapters.

(f) Provide each member of the Executive Council on or about the first of February of each year with a statement showing the financial condition of the Association for the first six months of operations in the fiscal year.

(g) Be responsible for:

(1) Reimbursing each Council member and officer who was present at the Convention, and each Host Chapter of the Convention for authorized expenditures in connection therewith.

(2) Collecting from the Treasurer of each Chapter the stated amount of the initiation fee payable to the Association for each initiate, less any refunds due the Chapter. See Bylaw V, Sec. 5.03(e)(1).

(3) Selling badges, official jewelry, and other supplies to the Chapters and members of the Association. See Const. Art. I, Secs. 3-7.

(4) Transmitting semiannually to the trustee all moneys collected in the previous six months for any of the funds under its trusteeship. See C. Arts. X and XI; and B-IX, Sec. 9.05.

(5) Assessing and collecting fines as specified in the Constitution. See Const. Art. IX, Sec. 3; and Bylaw VIII.

(6) Receiving, and holding for later payment, income on funds under the trustee that are ordered paid to the Secretary-Treasurer, and paying such sums as the Executive Council shall order. See Const. Arts. X, XI, XII, XV, and XVI.

(7) Administering the Student Loan Fund and issuing moneys in accordance with the rules for student loans upon concurrence of the President with later concurrence of the Executive Council. See Const. Art. XIII.

(8) Paying the stipends to recipients of fellowships and scholarships as directed by the Director of Fellowships. See Bylaws X, Sec. 10.08, and XI, Sec. 11.07.

(h) Pay out, from a fund designated for that purpose, operating expenses authorized by the Executive Council. All expenditures from this fund shall be reported to the Executive Council through the President.

(i) Have an audit made of the accounts of the Association after the close of the fiscal year by a Certified Public Accountant. Copies of the Secretary-Treasurer's report and the Auditor's report shall be provided to each member of the Executive Council at least one month before the Convention. These reports, together with explanatory statements, shall also be provided to each delegate to the Convention.

(j) Upon request from the proposing Chapter, promptly transmit all Convention proposals to the delegates in the form received from the proposing Chapter. (Such proposal shall not be longer than three 8 1/2-inch by 11-inch (22cm by 28cm) typewritten pages.)

(k) Conduct the Annual Collegiate Chapter Survey.

(l) Advise Chapters on acceptable projects and activities and collect information on them for the use of all Chapters.

(m) Prepare a program of discussions, lectures, and exhibits on Chapter projects and activities and supervise its conduct at the Convention.

(n) Collect information on Collegiate and Alumnus Chapter activities for publication.

**SECTION 3.02. Assistant Secretary-Treasurer.** The Assistant Secretary-Treasurer shall perform those official duties assigned by the Secretary-Treasurer.

### B-III, 3.03

SECTION 3.03. **Director of Rituals.** The Director of Rituals shall, with discretion, prepare and recommend changes in the rituals to the Convention and shall be responsible for the initiation equipment and any recommendations for changes. The Director of Rituals shall organize and supervise the Model Initiation at the Convention. See Const. Art. IV, Sec. 2(g)(1); and Bylaw I, Sec. 1.07.

SECTION 3.04. **Director of Fellowships.** The Director of Fellowships shall establish rules and regulations relative to the award of fellowships and scholarships, the method of consideration of candidates, and the operation of the fellowship and scholarship plans, subject to the Constitution and Bylaws of the Association and to the approval of the Executive Council. The Director of Fellowships shall provide each member of the Executive Council with a copy of all rules and regulations. See Const. Art. IV, Sec. 2(g)(2).

SECTION 3.05. **District Directors.** The District Directors shall meet with the representatives of the Chapters at the Convention; shall encourage uniform interpretation of the Constitution and Bylaws by the Chapters; and shall determine weaknesses of the Chapters in their Districts and focus resources to correct them. See Const. Art. IV, Sec. 2(g)(3).

SECTION 3.06. **Director of Engineering Futures.** The Director of Engineering Futures shall coordinate and select the content of the Engineering Futures curriculum and the schedule of presentations by facilitators to the Chapters. See Const. Art. IV, Sec. 2(g)(4).

## Bylaw IV

### *Establishment of Collegiate Chapters*

SECTION 4.01. **Petition.** (a) In addition to complying with Article VI of the Constitution of this Association, a petition for a Charter and the establishment of a Chapter at an institution must set forth:

(1) The requirements for admission to the entering class of the institution.

(2) The net number of weeks required to be spent on the campus in strictly academic classroom and laboratory work, exclusive of examination periods, for a first degree in engineering.

(3) The gross length of the college curriculum for a first degree in engineering.

(b) The petition shall give in tabular or graphical form, or both, the numbers of regular engineering students in each of the engineering classes and the names and numbers of the undergraduate engineering degrees awarded in each curriculum during the last five years.

(c) A copy of the petition, marked copies of the college's catalog or bulletin which are descriptive of the curricula and courses offered, and the equipment available for student use, and such other printed matter as may be available and which will be helpful to the Executive Council in reaching its decision, shall be submitted for each member of the Council and for the Secretary-Treasurer, with extra copies for inspectors.

(d) The petition shall give the professional, scientific, technical, and honor societies to which each member of the engineering faculty belongs.

(e) A group of students of an institution should not petition for a Charter if:

(1) The institution confers less than 40 strictly engineering bachelor's degrees each year; or,

(2) Its numbers of students are tending to decrease to or below this minimum limit; or,

(3) The institution gives degrees in fewer than three undergraduate engineering curricula, which have been accredited by the Engineering Accreditation Commission of the Accreditation Board for Engineering and Technology (ABET) or by an ABET-approved agency (exclusive of curricula in pure science and architecture), unless the institution offers three or fewer such curricula, all of which are accredited by ABET or by an ABET-approved agency; or,

(4) The petitioning group of students has not been organized and operated as a local society patterned after a Tau Beta Pi Chapter, and so proved its intentions for at least two full years after the adoption of a charter and installation of charter members; or,

(5) The petitioning group cannot be represented at the Convention by at least one alumnus or member of the faculty and preferably by one who is a member of the Association, and also by a member of the petitioning group; or,

(6) There are not at least three members of the faculty who are members of the Association; or,

(7) A majority of the engineering professors and associate professors are not members of their respective technical, professional, and scientific national societies; or,

(8) A complete preliminary petition cannot be submitted prior to the June 1 deadline.

**SECTION 4.02. Inspection.** Before approving, conditionally approving, or disapproving the preliminary petition for a charter, the Executive Council shall:

(a) Delegate one of its members, and/or other well-qualified representative, preferably the Secretary-Treasurer, to visit and inspect the institution as a whole as well as the engineering departments from whose students a petition has been received.

(b) Request neighboring chapters, if practicable, to send visiting delegations to inspect the institution with the representative(s) of the Council.

(c) Require the Inspection Committee, upon completion of the inspection visit, to submit a written report to the Council with recommendation for: (1) Approval. (2) Conditional approval (based upon specific reasons), or (3) Disapproval.

(d) Obtain the written opinions of members of the Association living in the vicinity as to the reputation of the institution and of its engineering departments.

(e) Obtain, if practicable, the written opinions of the membership of the neighboring Chapters as to the qualifications of the petitioners for membership in the Association.

## **Bylaw V**

### *Collegiate Chapters*

**SECTION 5.01. Election of Officers.** (a) There shall be an election of Chapter officers as early in the calendar year as conditions allow. They shall take office at least one month before the annual spring convocation or commencement. The policy of holding one additional election each year may be established with the approval of the Chapter's Advisory Board at the discretion of the Chapter. Officer vacancies shall be filled in accordance with the Chapter's officer-election procedure.

(b) The retiring officers shall turn over all the records to their successors and these records shall be up-to-date in all regards. It shall be the first duty of all incoming officers to familiarize themselves with these records and to see that they are in good order and up-to-date, and, if not, to try to get the cooperation of their predecessors before the latter leave college permanently.

(c) The records shall include the roll and record books, the minutes of the meetings of the Chapter for the current and previous years, the Treasurer's accounts for the current and previous years, the files of the Corresponding and Recording Secretaries, holders containing a complete file of the copies of THE BENT and of THE BULLETIN for the last three years, the card or other catalogs of the active and inactive members and of the alumnus members of the Chapter, and a correct and itemized list of the paraphernalia and other properties of the Chapter pertaining to the initiation ceremonies with note as to their place of storage. Older issues of THE BENT may be offered to the library of the institution.

(d) An elected officer of the Chapter may be removed for cause. Sufficient cause for removal may include, but is not limited to: having continued unexcused absences from the meetings of the Chapter; not attending to assigned or elected duties of the Chapter; inexcusably failing to meet financial obligations to the Chapter; violating the Constitution and Bylaws of the Association or the Bylaws of the Chapter; violating a rule, practice, or procedure adopted by the Chapter; or displaying conduct deemed contrary to the interests of the Chapter.

(1) Any member(s) who wish(es) to remove an alleged offending officer shall notify a Chapter Advisor, who shall convene a meeting of the Advisory Board to consider the charge(s). Any charged officer who is a member of the Advisory Board shall be excluded from the meeting.

(2) If the Advisory Board decides that a charge has merit which warrants removal from office, the charged officer will be suspended from all duties as an officer. The Advisory Board shall provide the officer in question with the opportunity to defend the charge(s) in a formal hearing at which counsel may represent the charged officer.

B-V, 5.01 (d)(3)

(3) The Advisory Board shall adopt rules and format to ensure due process, compose a statement of charge(s), notify the charged officer that a suspension has occurred, and establish a time and place for the hearing where the charge(s) will be considered. At least 21 days in advance of the hearing date, the Chapter must notify the Secretary-Treasurer and confirm that the charged officer has received these items or send them by registered mail to the last recorded address of the charged officer.

(4) After the hearing has been conducted and considered, the Advisory Board shall, by majority vote, recommend whether or not to remove the charged officer. The Advisory Board shall call a meeting of the active membership at which it will present its recommendation.

(5) The Chapter may remove the charged officer by a two-thirds vote from at least one-half of the active members of the Chapter. Unless a majority votes to remove the charged officer, he or she shall be reinstated to office immediately.

(6) A removed officer may appeal the decision to the Executive Council.

(7) If a charged officer resigns from office at any time during this process, the removal process shall cease immediately.

**SECTION 5.02. Standing Committees.** Each Chapter shall have standing committees on Membership, Initiation, Program, Social Activities, and such other committees as the Chapter shall desire and establish. Except by special Chapter action by three-fourths majority vote, the President of the Chapter shall decide upon the size of each of the committees and shall appoint its membership, preferably after conference with the appointed chair of the committee.

**SECTION 5.03. Duties of Officers.** (a) It shall be the duty of the President, as the responsible agent and leader of the Chapter, to see that the other officers of the Chapter perform their duties in accordance with the Constitution and Bylaws of the Association and the Bylaws of the Chapter.

(b) The Vice President of the Chapter shall be the chair of the Program Committee and shall have as a special duty the advancement of the technical and professional education of the active members.

(c) It shall be the duty of the Recording Secretary to keep the roll and record books of the Chapter as obtained from the Secretary of the Association, the minutes of the meetings of the Chapter completely written up-to-date and to keep in a suitable holder all the issues of THE BENT for the last three years and also in a similar holder all issues of THE BULLETIN for the last three years for the use of the members of the Chapter.

(d) It shall be the duty of the Corresponding Secretary of each Chapter to:

(1) Send promptly in October each year to the Secretary-Treasurer of the Association lists of the names and post-office addresses of the officers of the Chapter and to report promptly all changes in this information which may occur during the year. See B. VIII, Sec. 8.01(a), (b).

(2) Send to the Secretary-Treasurer of the Association the Report of Eligibility as specified in Bylaw VI, Sec. 6.05(a). See Bylaw VIII, Sec. 8.01(c).

(3) Send to the Secretary-Treasurer of the Association the Report of Election and card forms entitled Tau Beta Pi Catalog Card as specified in Bylaw VI, Sec. 6.05(b). See Bylaw VIII, Sec. 8.01(d).

(4) Send to the Secretary-Treasurer of the Association the Report of Final Action as specified in Bylaws VI, Sec. 6.05(c), and VII, Sec. 7.07. See Bylaw VIII, Sec. 8.01(e).

(5) Send to the Secretary-Treasurer of the Association, immediately upon receipt of the proper form or after their election, a duplicate of the credentials for the delegate and alternate to the ensuing Convention. See Bylaw VIII, Sec. 8.01(f).

(6) Furnish to the Secretary-Treasurer of the Association a copy of the Chapter's Bylaws, amended to date, with the written approval of the Advisory Board within two weeks of their adoption and amendment. See Bylaw VIII, Sec. 8.01(g).

(7) Report to the Secretary-Treasurer of the Association a receipt from the IRS for the appropriate 990 form as required. See Bylaw VIII, Sec. 8.01(h).

(8) Report to the Secretary-Treasurer of the Association such items of news and of interest as to honors received, offices to which members of the Chapter have been elected, and the like, and also any cases of discipline which might affect the standing of one or more members on the rolls of the Association.

(9) Carry on such other correspondence of the Chapter as the President may direct.

(10) Report to the Secretary-Treasurer of the Association any and all actions taken by the Advisory Board of the Chapter.

(e) (1) Within two weeks after each initiation, the Chapter, through its Treasurer, shall remit to the Secretary-Treasurer of the Association the stated amount of the initiation fee payable to the Association for each new initiate. See Bylaw VII, Sec. 7.04. This remittance shall cover the costs of the badge, certificate of membership, a four-year subscription to THE BENT, a copy of the Constitution and Bylaws and other approved literature of the Association. It shall also include a sum for the necessary expenses of the Association, including the cost of publishing THE BULLETIN. The initiation fee shall be determined by the Convention, on recommendation of the Executive Council. Within two weeks after each initiation, the Chapter shall also remit to the Secretary-Treasurer the stated amount of the Convention assessment payable to the Association for each new initiate. See B-I, Sec. 1.05.

(2) Except when the rules of the institution require that the Treasurer of a Chapter keep its financial accounts in a specified way and form, the official bookkeeping system of the Association on standard forms furnished by the Secretary-Treasurer of the Association shall be used and followed.

(3) For any candidate not initiated, the Chapter shall be refunded or credited, as it may elect, the full amount of the remittance, excepting the actual cost of the certificate if it shall have been engrossed and of the badge if it shall have been engraved.

(f) The Cataloger of each Chapter shall keep an up-to-date catalog of its active and alumnus members, giving the full name, the home address, and the college address of each member and the names of the officers of the Chapter, including the Advisory Board.

(g) It shall be the duty of every member to assure that each elective officer of the Chapter conscientiously performs the duties of the office for the benefit of the entire Chapter, particularly in matters pertaining to finance and the relations of the Chapter with the Secretary-Treasurer of the Association, and to take appropriate action when an elected officer fails to perform the duties of the office. See Bylaw V, Sec. 5.01 (d).

(h) The primary duty of the alumnus advisors is to provide for continuity of Chapter operations. The alumnus advisors shall see that the Chapter: (1) Selects candidates who meet the eligibility requirements of Constitution Article VIII, the bylaws of the Chapter, and the academic regulations of the host institution. (2) Balances its financial accounts and pays all bills by the end of the academic year. (3) Effects an orderly transition of Chapter officers in accordance with Bylaw V, Sec. 5.01.

**SECTION 5.04. Chapter Finances.** (a) The expenses of a Chapter shall be borne by the initiation fees, by dues to be paid each quarter, term, or semester, and by any assessments that the Chapter may decide. These assessments may be voted at any regular meeting of the Chapter by a three-fourths affirmative vote of all the active Chapter membership eligible to vote thereon, subject, on appeal, to the approval of the Advisory Board of the Chapter. See Con. Art. VI, Sec. 1.

(b) Each Chapter shall decide on the amount of its initiation fee (including the stated amount of the initiation fee payable to the Secretary-Treasurer of the Association) and on its dues per quarter, term, or semester. See Const. Art. VI, Sec. 1.

(c) The budget of the estimated expenses of the Chapter for the next college year shall be prepared in March or April by the officers of the Chapter. It shall be the special order of business of one of the regular April meetings of the Chapter. It shall include all of the expenses of the initiation ceremonies, dinners, luncheons, picnics, dances, and other social activities, back debts, prizes and awards, auditor and bank charges, loans to electees, Convention assessment, rents, supplies, long-distance telephone calls, stationery, postage, etc.

**SECTION 5.05. Convention Delegate.** (a) At one of the regular April meetings of the Chapter, after canvassing the subject to find out who can most conveniently go to, and to consider who will most satisfactorily represent the Chapter at, the next regular Convention of the Association, the Chapter's Convention delegate and an alternate shall be elected by the active members of the Chapter. See Bylaw I, Sec. 1.04.

B-V, 5.05 (b)

(b) On the delegate's return from the Convention, it shall be the delegate's duty to make a general report, preferably in writing, to the Chapter at its next regular meeting on the business transacted by the Convention, the entertainment received, and impressions of the Convention and the delegates, with suggestions for the improvement of the life and work of the Chapter and its members.

**SECTION 5.06. District Activities.** The Chapter shall cooperate with the Director(s) of the District to which it is assigned; shall inform the Director(s) of its activities; and shall participate in the activities of its District to the extent of the capability of its members.

**SECTION 5.07. Quorum.** A quorum for the consideration of routine business shall consist of one-half the active membership of the Chapter; for the election of new members, for the revocation of election, for changing the initiation fee or Chapter dues, and for the passing of an assessment on the members of the Chapter, three-fourths of the active chapter membership eligible to vote thereon; and for the approval or disapproval of a proposed amendment to the Constitution or Bylaws of the Association or Chapter, three-fourths of the active members of the Chapter. See Const. Art. VI, Sec. 1. Chapters located at colleges operating on a cooperative basis and those chapters with evening division members may be granted permission by the Executive Council to lower the requirements listed above for a quorum.

## **Bylaw VI**

### *Election of Members*

**SECTION 6.01. Election Periods.** (a) A Chapter shall hold one, two, or three elections of new members each year, the program of each Chapter being subject to the approval of its Advisory Board. See Const. Art. VIII, Sec. 1(d). An initiation shall follow each election and shall not be delayed unnecessarily. The Chapter's program shall be reported promptly to the Secretary-Treasurer of the Association. Other deviations from the above schedules may be permitted for good and sufficient reason with the consent of the Advisory Board of the Chapter and the approval of the Executive Council.

(b) Special elections and/or initiations of undergraduate members can be held only for good and sufficient reasons and after the unanimous consent of the Advisory Board of the Chapter has been obtained. The written consent of the Advisory Board for a special election shall be sent to the Secretary-Treasurer of the Association with the names of the candidates. See Const. Art. VIII, Sec. 1(e).

**SECTION 6.02. Compilation of Data.** (a) The membership committee of the Chapter shall obtain from the proper officer of the college the names and records of all students likely to be in the upper fifth of the regular senior class in engineering and the upper eighth of the regular junior class in engineering, at the time of the election. See Const. Art. VIII, Sec. 2. Such students shall be considered collectively as class groups, without regard to departmental specialization, except as provided in Constitution Article VIII, Section 2(b). Care must be taken not to overlook anyone.

(b)(1) In computing one-eighth or one-fifth of the total enrollment of the regular junior and senior classes in engineering, any fraction shall be considered an integer. If the lower limit of one-eighth or one-fifth of the total enrollment falls within a group of students who have the same point rating, all such names shall be included in the list without distinction.

(2) Members elected as from a certain class (normally expecting to graduate at the same time) who drop back to a later class shall not be counted with that later class, nor in the quota(s) therefrom, when reckoning the quotas for purposes of election.

(3) Undergraduate members who have transferred from other Chapters shall not be counted, as explained in Section 6.02(b) (2) above.

(4) Sizes of classes in day and evening curricula, and the eligible quotas therefrom, shall be reckoned separately.

(c) Averages, if available, shall be computed for these students on a basis (depending on the system of grading in the particular institution) which shall show clearly their scholastic ratings.

(d) These averages shall be computed on the point system. The total number of hours taken and points earned shall be determined for each year of the curriculum in accordance with this system. Credits obtained elsewhere, if included, should be counted according to actual grades originally made and not by grades allowed by the second institution. See Const. Art. VIII, Sec. 2(1). Credits obtained by examination, unless graded according to quality, shall not be considered in computing the point ratio. The number of hours of credit for a particular course shall be multiplied by a number which shall indicate the quality of the work done; for example, the number of hours of a course done with a grade of Excellent, Merit, or "A" shall be multiplied by a constant such as four in making up the point ratio. Similarly, grades such as Good, "G," or "B" shall be multiplied by some such number as three; grades such as average, fair, or "C" shall be multiplied by some such number as two; grades such as "D," poor, "P," or passing, and nothing more, shall be multiplied by a constant such as one; grades below passing shall be counted as hours but not as points. The total of product-points so obtained shall be divided by the total of product-hours for the two or more years to obtain the point ratio of a student. "Incomplete" and "deferred" grades shall not be considered or counted. If desired, the point ratios may be weighted so as to give more emphasis to grades earned beyond the first year of the college curriculum.

(e) A Chapter may have a higher standard than that prescribed by the Constitution if the Executive Council approves a petition which shall include an explanatory letter of justification for the amendment to its Chapter's Bylaws. See Bylaw V, Sec. 5.03(d) (6).

(f) A Chapter shall have a procedure for the evaluation of the exemplary character of candidates as enunciated in the Eligibility Code of the Association. This procedure shall be submitted to and approved by the Executive Council, and shall be contained in the Chapter's Bylaws. This procedure may be modeled after the examples suggested by the Executive Council or Convention or designed by the Chapter, subject to the approval of the Executive Council. The decision of the Executive Council may be appealed to the next Convention whose decision will be final.

(g) In the event that the Executive Council disapproves a Chapter's procedure, the Executive Council shall direct the Chapter to follow a procedure the Council deems appropriate until such time as the Chapter obtains its approved method.

**SECTION 6.03. Election.** (a) (1) Each Chapter shall approve an election procedure consistent with its methods of measuring exemplary character which shall include the reading of the Eligibility Code at the time of election. (See Sec. 6.02(f)). This procedure may provide for voting on each name before consideration of the next name, or for voting on groups of names recommended to the Chapter by its character measurement process, or for such devices as desired by the Chapter as long as the procedure considers the candidates individually at some point in the character measurement process and conforms to Section 6.03(b). This election procedure of the Chapter must be approved by the Executive Council and be contained in the Chapter's Bylaws.

(2) After all scholastically eligible candidates have been considered and voted on, there shall be a second individual ballot, taken by order of class rank (seniors first, juniors last) for each student who failed election on the first ballot. No student who fails election on the second ballot shall be considered further unless twenty-five percent of the voting members present so request. No student who fails election on the third ballot shall be considered again at this election. Any such students may be considered at subsequent elections if they are then eligible.

(3) When following the procedure of voting on the candidates as a group, if any member objects to the election of a candidate, that candidate's name shall be removed from the group. A vote shall be taken on the remainder of the group. After this group has been voted on, each candidate so removed shall be reconsidered and voted on individually as outlined in Section 6.03(a) (1) and (2).

B-VI, 6.03 (b)

(b) (1) Anyone eligible under Constitution Article VIII must be elected by an affirmative vote of at least three-fourths of the active Chapter membership eligible to vote thereon, who are present and voting affirmatively or negatively, except as provided for in Constitution Article VIII, Sections 4(a) (4) and 5(a) (4). In each case the total affirmative vote must be a majority of the active chapter membership eligible to vote thereon. See Const. Art. VI, Sec. 1. In computing these ratios any fraction one-half or greater shall be counted as a whole number.

(2) Graduate students eligible under Constitution Article VIII, Section 3, shall be voted on separately from the undergraduate students.

(c) The election of members shall be by secret ballot and shall be conducted by the President of the Chapter, or by a member of the Advisory Board or by an alumnus member designated by the President. The term "secret ballot" shall be interpreted to mean that no active member shall see how any other member voted. See Const. Art. VIII, Sec. 1(c).

(d) Students who may have been overlooked at a regular election and students who may have been considered and not elected at the regular autumn or winter (or spring) election may be reconsidered and elected at a subsequent election, as if never previously considered, provided they are still eligible under the Constitution and Bylaws.

**SECTION 6.04. Revocation of Election.** (a) An individual who has been elected to membership, but has not yet been initiated, shall be known as an electee. If an electee fails to complete any required activities or duties (see B. VII, Sec 7.01 and 7.02) or in another way exhibits character that is less than exemplary, the Chapter may revoke the election of that individual.

(b) Each Chapter shall approve a revocation procedure consistent with its methods of measuring exemplary character which shall include the reading of the Eligibility Code at the time of revocation. (See Sec. 6.02(f)). This procedure may provide for voting on each name before consideration of the next name, or for voting on groups of names recommended to the Chapter by its character measurement process, or for such devices as desired by the Chapter as long as the procedure considers the candidates individually at some point in the character measurement process and conforms to Section 6.04(c). This revocation procedure of the Chapter must be approved by the Executive Council and be contained in the Chapter's Bylaws.

(c)(1) Any electee can have his/her election revoked by an affirmative vote of at least three-fourths of the active Chapter membership eligible to vote thereon, who are present and voting affirmatively or negatively, except as provided for in Constitution Article VIII, Sections 4(a) (4) and 5(a) (4). In each case the total affirmative vote must be a majority of the active chapter membership eligible to vote thereon. See Const. Art. VI, Sec. 1. In computing these ratios any fraction one-half or greater shall be counted as a whole number.

(2) Graduate students eligible under Constitution Article VIII, Section 3, shall be voted on separately from the undergraduate students.

(d) The revocation of the election of an electee shall be by secret ballot and shall be conducted by the President of the Chapter, or by a member of the Advisory Board or by an alumnus member designated by the President. The term 'secret ballot' shall be interpreted to mean that no active member shall see how any other member voted. See Const. Art. VIII, Sec. 1(c).

(e) Any student whose election has been revoked may be considered at subsequent elections if he or she is then eligible.

**SECTION 6.05. Records and Reports.** (a) A list of the eligible candidates, including all those in the top fifth of the senior class and top eighth of the junior class (candidates and present chapter members, by name), indicating the class of each person, shall be made on the official form entitled Report of Eligibility. Appended to the Report of Eligibility should be a list of the names and qualifications of any graduate-student, alumnus, or eminent-engineer candidates being considered for membership. This report shall be sent to the Secretary-Treasurer of the Association as soon as the information is available. Requirements for copies of the Constitution and Bylaws and other literature and record materials for the

expected number of electees shall be stated on this report. See Bylaws V, Sec. 5.03(d) (2); and VIII, Sec. 8.01(c).

(b) A list of the electees who have accepted membership, giving full names, scheduled times of graduation, and their expected initiation date, shall be made on the official form entitled Report of Election. A personally completed record of each electee who has accepted membership shall be made on the official card form entitled Tau Beta Pi Catalog Card. The Report of Election and the Catalog Cards shall be sent to the Secretary-Treasurer of the Association, to arrive no later than two weeks before the expected date of initiation. They shall include full necessary data on any graduate-student, alumnus, or eminent engineer electees if such have not previously been submitted. Initiation shall not be permitted without the approval by email or telegram from the Secretary-Treasurer of the Association of the list of electees on the Report of Election and the Catalog Cards. Badges and certificates of membership for the electees will be ordered by the Secretary-Treasurer of the Association from these reports. See Bylaws V, Sec. 5.03(d) (3); VIII, Sec. 8.01(d) and Sec. 8.04.

(c) A list of the eligible candidates above the Chapter deadline, if any, and including any graduate-student, alumnus, or eminent-engineer candidates, shall be made on the official form entitled Report of Final Action and shall be sent to the Secretary-Treasurer of the Association immediately after each initiation. This report shall indicate for each candidate the election or rejection for membership by the Chapter, acceptance or refusal of membership by the candidate, and whether each elected candidate has been initiated, has not been initiated, or has received a postponement. Where appropriate, it shall also give the reason for rejection or refusal, and the expected date of initiation for each postponement. This report shall be accompanied by a photocopy of the Chapter's Roll Book page(s) bearing the signatures of the persons actually initiated, as a validation of their membership. See Bylaw V, Sec. 5.03(d) (4); VII, Sec. 7.09; and VIII, Sec. 8.01(e).

**SECTION 6.06. Inactive Status.** (a) An active member shall become inactive upon withdrawal from college or because of illness or accidental disability lasting over two months. On returning to college, the member shall immediately become active.

(b) An active member will become inactive by the affirmative vote of five-sevenths of the Advisory Board or as provided in the Chapter's Bylaws. Such a member will be re-admitted to active status upon receipt of a written petition and its approval by the Advisory Board.

(c) Chapters should report the number of members affected and the reason for their change of status to the Secretary-Treasurer of the Association within two weeks of the Advisory Board's decision.

**SECTION 6.07. Transfer of Chapter.** An undergraduate member, on transferring to another institution where there is a Chapter of the Association, shall immediately become an active member of that Chapter. See Const. Art. VI, Sec. 1.

**SECTION 6.08. Payments by Active Members.** As long as a person is an active member of a Chapter, that person shall pay to the Chapter all dues, assessments, and fines payable by the active members of that Chapter.

## **Bylaw VII**

### *Initiation*

**SECTION 7.01. Electee Activities.** Each chapter shall require of its student electees their participation in an activity recommended or approved by the Chapter officers to foster a spirit of liberal culture. This activity may take the form of a project and/or writing an essay of not less than 500 words upon a topic suggested or approved by the Advisory Board of the Chapter.

**SECTION 7.02. Electee Duties.** (a) While duties for the electees are permissible, they shall be limited to tasks and duties that are a test of an electee's intellectuality and mentality rather than physical strength and endurance and shall not consume an inordinate amount of time to the possible detriment of required college work. Physical violence, offense to dignity

B-VII, 7.02(a)

or decency, or public exercises that demean the electee in any way shall not be permitted. The expense of any electee activity shall be carefully considered and not be prohibitory to the Chapter or the electee.

(b) If an electee objects to the required duties and the chapter cannot resolve the objection, the electee may appeal to the Advisory Board of the Chapter. If the electee is not satisfied with the outcome, the electee will be given contact information for the District Director, who will advise the parties on resolution.

**SECTION 7.03. Constitution and Bylaws.** Each electee shall be required to read the Constitution and the Bylaws of The Tau Beta Pi Association before being initiated.

**SECTION 7.04. Initiation Fee.** (a) An electee shall not be initiated without paying the initiation fees in full. In special cases this provision may be waived, with the approval of the Chapter's Advisory Board, for an electee who has signed a promissory note covering the initiation fees and any other indebtedness to the Association.

(b) The Chapter shall be financially responsible to the Association for the collection and payment to the Association of the initiation fees of each initiate which are payable to the Association. See Bylaw V, Sec. 5.03(e).

**SECTION 7.05. Roll Book.** Initiates shall sign their names in the Roll Book of the Chapter as a part of the initiation ceremony. Each sheet of the Roll Book shall have as a caption the pledge to support the Constitution, Bylaws, and ideals of The Tau Beta Pi Association.

**SECTION 7.06. Certificate and Badge.** Each initiate shall be given a certificate of membership, a badge, and a copy of the Constitution and Bylaws.

**SECTION 7.07. Reports.** Reports of the initiation and such other matters pertaining thereto in accordance with Bylaws V and VI shall be provided to the Secretary-Treasurer of the Association promptly after each initiation on the official form entitled Report of Final Action. See Bylaw VIII, Sec. 8.01(e).

**SECTION 7.08. Joint Activities.** Joint dinners, luncheons, and dances may be held with other organizations by formal approval of the Chapter and the Advisory Board. Joint initiation ceremonies with fraternities, other associations, or societies are prohibited.

**SECTION 7.09. Initiation Postponement.** Postponement of an electee's initiation must be approved by the Advisory Board. (See Bylaw VI, Sec. 6.05(c)). (a) Eligible Electee. An electee who remains eligible may be initiated at the next regular initiation without re-election. Such an electee who graduates may be initiated without re-election within five years from the date of election. (b) Ineligible Electee. (1) An electee who becomes ineligible and whose initiation has been postponed may be initiated at the next regular initiation without re-election. (2) An electee who becomes ineligible and whose initiation has not been postponed must become eligible and be re-elected during a subsequent term to be initiated.

## Bylaw VIII

### *Fines*

**SECTION 8.01. Failure to Report.** A Chapter that fails to report or to send to the Secretary-Treasurer within two weeks of the time indicated information required by the Constitution and/or Bylaws shall be assessed and shall pay the following fines (see Bylaw V, Sec. 5.03(d) (1-7)):

(a) Five dollars (\$5.00) on the addresses of the Chapter officers.

(b) Five dollars (\$5.00) on the election of Chapter officers and new members of the Advisory Board.

(c) Five dollars (\$5.00) on the list of candidates eligible for membership, on the official form entitled Report of Eligibility, filled in as specified in Bylaw VI, Section 6.05(a), within the first five weeks after the opening of the college year in the autumn, and within the first five weeks of the second semester, or term, or of the winter (or spring) quarter of the college year.

(d) Five dollars (\$5.00) on the list of electees who have accepted membership, on the official form entitled Report of Election, and on the official card form entitled Tau Beta Pi Catalog Card, filled in as specified in Bylaw VI, Section 6.05(b), to reach the Secretary-Treasurer of the Association no later than two weeks before the expected date of initiation.

(e) Five dollars (\$5.00) on the Report of Final Action on eligible candidates, filled in as specified by Bylaw VI, Sec. 6.05(c), and copy of the Chapter's Roll Book page(s), within two weeks after the initiation of new members.

(f) Five dollars (\$5.00) on a duplicate of the credentials for the Convention delegate and alternate.

(g) Five dollars (\$5.00) on a copy of the active Bylaws of the Chapter, as approved by the Advisory Board.

(h) Five dollars (\$5.00) on the receipt for the appropriate 990 form.

**SECTION 8.02. Unapproved Initiation.** A Chapter that holds an initiation ceremony for candidates elected under Constitution Article VIII, Section 2, without approval of the Secretary-Treasurer shall be assessed a flat fine of \$50.00. See Sec. 8.04 and Const. Art. IX, Sec. 2.

**SECTION 8.03. Initiation of Ineligible Candidate.** A Chapter that initiates a candidate who is ineligible under the Constitution and Bylaws shall be assessed a fine of twenty-five dollars (\$25.00) per ineligible initiate, not to exceed \$250.00 per initiation. See Const. Art. VIII, Sec. 11.

**SECTION 8.04. Lack of Proof of Worthiness.** A Chapter that initiates a candidate elected as a member under Constitution Article VIII, Sections 3, 4, 5, 6, and 7, without submitting proof of the worthiness of the candidate, without sending written approval of the Advisory Board of the Chapter to the Secretary-Treasurer of the Association, and without receiving the written approval of the election as required by Constitution Article VIII, Section 3 or 7(c), and Bylaw 6.05(b) shall be assessed a fine of twenty-five dollars (\$25.00) per ineligible initiate, not to exceed \$250.00 per initiation, and the Chapter, at the discretion of the Executive Council, shall be placed on probation. (Probation is defined in Const. Art. IX, Sec. 2.)

**SECTION 8.05. Failure to File the Appropriate IRS 990 form.** A chapter that fails to file the appropriate 990 form as required by the IRS for two consecutive fiscal years shall be assessed a flat fine of fifty dollars (\$50.00) and shall be required to report to the next Chapter and Association Financial Affairs Committee.

**SECTION 8.06. Failure to Comply.** These fines shall be increased the same amount for each failure of the Chapter to reply within two weeks to the request of the Secretary-Treasurer for the belated report or remittance.

**SECTION 8.07. Application.** The Secretary-Treasurer shall apply all fines automatically and without discrimination, and shall bill such fines to the Chapter as soon as the infractions for which fines may be assessed shall occur. If the Chapter can show reason why it should not be fined, the Secretary-Treasurer may reduce the fine.

**SECTION 8.08. Deadlines.** All deadlines referred to in these Bylaws shall be defined as the postmark date or international equivalent.

## **Bylaw IX**

### *Publications*

**SECTION 9.01. Names.** The official publications of the Association shall be known as THE BENT OF TAU BETA PI<sup>1</sup> and THE BULLETIN OF TAU BETA PI.

---

<sup>1</sup> ® Title registered in U.S. Patent and Trademark Office.

SECTION 9.02. **Editor.** The editor of the publications shall be the Secretary-Treasurer, who in such capacity shall be responsible to the Executive Council for the publications of the Association. See Bylaw III, Sec. 3.01(a).

SECTION 9.03. **Publication Schedule.** (a) THE BENT shall be published four times per year and shall contain reviews of actions of the Executive Council and the Convention, news of the Districts, the Chapters and the members, and items of general professional interest.

(b) THE BULLETIN shall be published three times per year and shall contain messages from the Executive Council and other officers of the Association, matters of general interest relating to District activities, Chapter operation, and other pertinent material. THE BULLETIN shall be distributed to all members of the Collegiate Chapters.

SECTION 9.04. **Subscription Fee.** The subscription price of THE BENT shall be \$2.10 per year for undergraduate members and \$10.00 per year for alumnus members and other persons. The Executive Council may, from time to time, authorize special rates to non-subscribers for the purpose of establishing a broader interest in the affairs of the Association. Any member may become a life subscriber to THE BENT on payment of \$60.00 in one payment or of \$62.50 in five annual payments of \$12.50 each, of which 50 cents per year shall be used for operating expenses. Each Chapter shall subscribe to THE BENT for four years for each initiate. The subscription charge of \$8.40 shall be a part of the initiation fee, but the initiate may elect to pay \$51.60 additional fee, and so become a life subscriber to THE BENT. The subscription shall start from the first issue after initiation. Any member may at any time during the period of the initial four-year subscription convert the subscription to a life subscription by the payment of the difference of \$60.00 and any remaining prepaid subscription. (The desirability of becoming a life subscriber to THE BENT should be brought clearly to the attention of alumnus members and each initiate before the initiation in Chapter letters and other communications.)

SECTION 9.05. **Life Subscription Fund.** All moneys collected as life subscriptions to THE BENT shall be paid by the Secretary-Treasurer to the corporate trustee for incorporation into the Life Subscription Fund from which the income will be used by the Association to offset the cost of publication of THE BENT for Life Subscribers. Upon the death of a Life Subscriber, the Secretary-Treasurer shall transfer from the Life Subscription Fund to the Fellowship Fund the amount that the deceased Life Subscriber had paid. See C. Arts. X and XI.

## **Bylaw X**

### *Fellowships*

SECTION 10.01. **Establishment.** The Association shall maintain a program of fellowships insofar as the financial condition of the Association permits in the opinion of the Executive Council. The Executive Council shall determine the amount of the stipend for each fellowship in each year with the advice of the Director of Fellowships and shall determine the number of fellowships with stipend to be awarded each year, based on the total moneys available from income on the Fellowship Fund and the general financial condition of the Association. The Executive Council may use other funds of the Association if such use of funds appears to be warranted in view of other financial commitments of the Association. The Executive Council shall advise the Director of Fellowships not later than the first of November of each year the number and stipend of fellowships that will be available for the following year. A recipient of a fellowship must start full-time academic work within twelve months after the fellowship has been awarded. See C. IV, Sec. 2(g) (2).

SECTION 10.02. **Objective.** The object of the Fellowship Program shall be to advance the interest of the engineering profession, to stimulate graduate study and research and to recognize deserving members of the Association for demonstrating outstanding scholarship and exemplary character.

SECTION 10.03. **Eligibility Conditions.** (a) Fellowships shall be granted to members of the Association strictly for graduate work towards an advanced degree. The graduate study shall be in a field that enables the recipient to contribute to the engineering profession as determined by the Fellowship Board. The fellow shall pursue full-time study for the full college year of the institution at which the fellowship year will be spent.

(b) A fellowship shall not be awarded to a member who has previously had a Tau Beta Pi fellowship.

(c) Stipends shall not be awarded to those fellows who accept other substantial financial aid as determined by the Director of Fellowships.

SECTION 10.04. **Selection Criteria.** Fellowships shall be awarded on the basis of the applicant's scholastic attainment, proposed plan for graduate study toward a career objective, unselfish activity of a nature described in the Tau Beta Pi Eligibility Code, and references.

SECTION 10.05. **Certificate.** Each recipient of a Tau Beta Pi fellowship, with or without stipend, shall receive a certificate at the beginning of the fellowship year, or shortly thereafter, which shall set forth the full names of the recipient, Chapter, alma mater, and the institution at which advanced work will be done, and the year for which the fellowship is awarded. The certificate shall be signed by the Director of Fellowships, the President, and the Secretary-Treasurer of the Association.

SECTION 10.06. **Resignation.** If a fellow does not continue a degree program for any reason, the fellow shall promptly resign the fellowship and shall relinquish the financial claim on the Association one month after submitting the resignation. If a fellow encounters unusual circumstances that would force resignation, the fellow may appeal to the Fellowship Board for reconsideration of the fellowship plan.

SECTION 10.07. **Payment.** The stipend shall be the same for all fellowships with stipend awarded in any one year, but may be changed from year to year. The Secretary-Treasurer of the Association shall pay to each of the fellows the amount of the stipend in ten monthly installments on the fifteenth of each month, or in another manner approved by the Executive Council. See Bylaw III, Sec. 3.01(g) (8).

SECTION 10.08. **Report of Fellows.** Each fellow shall make a suitable report to the Director of Fellowships near the end of the year for which the fellowship was granted. The report shall set forth briefly academic activities during the year, accomplishments, and suggestions for the betterment of the Fellowship Program.

SECTION 10.09. **Rules for Application.** The Director of Fellowships may make such rules and regulations relative to the application for fellowships, the consideration of candidates, the operation of the fellowship plan, and the reports of the fellows as may be deemed wise and desirable, subject to the Constitution and Bylaws and to the approval of the Executive Council.

## Bylaw XI

### *Scholarships*

**SECTION 11.01 Establishment.** The Association shall maintain a program of scholarships insofar as, in the opinion of the Executive Council, the financial condition of the Association permits. The Executive Council, with the advice of the Director of Fellowships, shall determine the amount of a full-term stipend and the total scholarship moneys to be awarded each year, based on the total moneys available from income on the Scholarship Fund and the general financial condition of the Association. The Executive Council may use other funds of the Association if such use of funds appears to be warranted in view of other financial commitments of the Association. The Executive Council shall advise the Director of Fellowships not later than the first of November of each year the amount of a full-term stipend and the total scholarship moneys that will be available for the following year. A recipient of a scholarship must enroll in full-time academic work within twelve months after the scholarship has been awarded. See C. IV, Sec. 2(g) (2).

**SECTION 11.02. Objective.** The object of the Scholarship Program shall be to advance the interest of the engineering profession, to stimulate undergraduate study and to recognize deserving members of the Association for demonstrating outstanding scholarship and exemplary character.

**SECTION 11.03. Eligibility Conditions.** (a) Scholarships shall be granted to members of the Association strictly for undergraduate work towards a bachelor's degree. The undergraduate study shall be in a program for which students are eligible for membership in Tau Beta Pi at an institution with an active Tau Beta Pi chapter. The scholar shall pursue full-time study for either a full term or a partial term as specified by the scholar. A full term is defined as the full college year of the institution. A partial term is defined as one semester, one trimester, or two quarters of the institution.

(b) A scholarship shall not be awarded to a member who has previously had a Tau Beta Pi Scholarship.

**SECTION 11.04. Selection Criteria.** Scholarships shall be awarded on the basis of the applicant's scholastic attainment, unselfish activity of a nature described in the Tau Beta Pi Eligibility Code, and references. Financial need may be considered in the awarding of scholarships.

**SECTION 11.05. Certificate.** Each recipient of a Tau Beta Pi Scholarship shall receive a certificate at the beginning of the scholarship year, or shortly thereafter, which shall set forth the full name of the recipient, Chapter, the institution name, and the year for which the scholarship is awarded. The Director of Fellowships, the President, and the Executive Director of the Association shall sign the certificate.

**SECTION 11.06. Resignation.** If a scholar does not continue a degree program for any reason, the scholar shall promptly resign the scholarship and shall relinquish the financial claim on the Association one month after submitting the resignation. If a scholar encounters unusual circumstances that would force resignation, the scholar may appeal to the Executive Council for reconsideration of the scholarship plan.

**SECTION 11.07. Payment.** The stipend amount shall be the same for each full-term scholarship awarded in any one year. The stipend amount for each partial-term scholarship shall be half of the stipend amount for a full-term scholarship in the same year. The Executive Director of the Association shall pay to each of the scholars the appropriate stipend amount in a manner approved by the Executive Council. See Bylaw III, Sec. 3.01 (g) (8).

**SECTION 11.08. Rules for Application.** The Director of Fellowships may make rules and regulations relative to the application for scholarships, the consideration of candidates, and the operation of the scholarship plan, subject to the Constitution and Bylaws and to the approval of the Executive Council.

## Bylaw XII

### *Laureates*

SECTION 12.01. **Objective.** A major purpose of the Association, as stated in the Preamble to the Constitution, is “. . . to foster a spirit of liberal culture in engineering colleges.” The Association shall maintain the Laureate Program to recognize members who have demonstrated through extensive activities that technology alone is not the sole concern of the engineer. This concern for liberal culture is reflected by the Laureate’s achievements while enrolled as a student of engineering. The object of the Laureate Program shall be to place a greater emphasis on fostering the spirit of liberal culture. Consideration shall be made on an annual basis.

SECTION 12.02. **Basis for Nomination.** Laureate awards are intended to honor student members who have made outstanding contributions in an area of liberal culture as interpreted by the Laureate Selection Committee such as Arts, Athletics, Diverse Achievements, or Service.

SECTION 12.03. **Nominations.** Any collegiate chapter may nominate one or more of its active student members as a Laureate candidate. The Secretary-Treasurer shall provide guidelines for the nomination package. This package shall be prepared by the chapter in consultation with the nominee.

SECTION 12.04. **Selection Committee.** The Laureate Selection Committee, comprised of District Directors appointed by the Executive Council, may select up to five Laureates with a maximum of two awards given in any one area.

SECTION 12.05. **Award and Recognition.** Each of the Laureates selected shall receive a cash award of an amount to be determined by the Executive Council. The names of the Laureates shall be announced at the Convention and their photographs and accomplishments published in THE BENT. A recognition plaque will be given to each Laureate. The Secretary-Treasurer of the Association shall arrange for an appropriate presentation of the plaque and cash award and arrange for media recognition. A recognition plaque will also be awarded to the Laureate’s nominating Chapter at the Convention.

SECTION 12.06. **Relationship to Other Awards.** The Laureate award is a grant based on nomination, with no stipulations relative to any other award, grant, or fellowship. An individual may not be selected as a Laureate more than once.

## Bylaw XIII

### *Student Loans*

SECTION 13.01. **Administration.** The Secretary-Treasurer of the Association shall administer student loans from the Student Loan Fund not to exceed \$2,500. The amount set aside to maintain the Initiation Fee Loan Fund shall not exceed \$2,500.

SECTION 13.02. **Application.** A member of the Association desiring a loan shall make application on a form to be provided by the Secretary-Treasurer of the Association. The application shall set forth the name and college address, as well as permanent address, of the applicant, the name and address of the applicant’s parent or guardian, and the amount of the loan requested. The application shall be certified as correct by the student’s faculty advisor or the head of the department under which the student is enrolled. The application shall also be certified by the President, Recording Secretary, and Treasurer of the local Chapter. Such certification shall indicate that the loan is needed in order for the applicant to complete the work toward a degree. The application, together with a promissory note, shall be transmitted to the Secretary-Treasurer of the Association for appropriate action.

SECTION 13.03. **Approval.** The Secretary-Treasurer shall determine whether the applicant is eligible to receive a student loan, whether the application is in proper order, and whether sufficient funds are available from which to make the loan. This information shall be certified to the President of the Association who shall approve or disapprove the application.

SECTION 13.04. **Payment.** Upon approval of a loan application and execution of the promissory note, the Secretary-Treasurer shall transmit to the applicant the amount of the loan requested. The rate of interest shall be as determined by the Executive Council. The period of the loan shall be for not more than three years, renewable at the discretion of the Executive Council upon written application thereto.

SECTION 13.05. **Rules and Regulations.** The Executive Council is empowered to make such additional rules and regulations relative to the making and repayment of student loans as in their judgment shall be proper.

## **Bylaw XIV**

### *Engineering Futures*

SECTION 14.01. **Objective.** The objective of Engineering Futures shall be to advance the interest of the engineering profession and to enhance the technical educational process by promoting the learning of interpersonal nontechnical skills which are essential for a well-rounded, effective engineer.

SECTION 14.02. **Curriculum.** The Engineering Futures curriculum will be comprised of materials designed to enhance the development of engineering students. The courses may be selected with consideration given to requests from industry.

SECTION 14.03. **Facilitators.** The Engineering Futures facilitators shall be appointed by the Executive Council to serve staggered terms of three years beginning July 1st. They shall be alumnus members of the Association, shall serve without compensation, and may be reappointed. They shall be trained to present the Engineering Futures curriculum to Tau Beta Pi collegiate chapters. They may be reimbursed for reasonable expenses and for travel authorized by the Executive Council.

SECTION 14.04. **Presentations.** The Engineering Futures curriculum shall be presented by the Engineering Futures facilitators at no charge to the student members.

SECTION 14.05. **Restrictions.** To avoid any competition with vendors, the Engineering Futures curriculum may be offered only under the sponsorship of a Tau Beta Pi collegiate chapter and may be addressed only to collegiate students.

## **Bylaw XV**

### *Amendments*

SECTION 15.01. **Proposal.** An amendment to the Bylaws may be proposed by the Executive Council or any undergraduate Chapter to the Convention Committee on Constitution and Bylaws, by a delegate directly to the Convention, or by the Convention Committee on Constitution and Bylaws directly to the Convention.

SECTION 15.02. **Adoption.** An amendment to the Bylaws proposed to any Convention may be adopted by the same Convention on any day following its formal presentation to the Convention by at least a three-fourths vote of those present and entitled to vote. Any proposed amendment may be laid over until the next succeeding Convention upon at least a three-fourths vote of those present and entitled to vote. Any proposed amendment may be referred to the Chapters upon at least a three-fourths vote of those present and entitled to vote. Ratification balloting on an amendment referred to the Chapters shall be conducted in accord with the procedures required for adoption of Constitution amendments (See Const. Art. XVIII, Sec. 2). Each Chapter must report its vote to the Secretary-Treasurer of the Association in accord with Constitution Article XVIII, Section 3, or it will forfeit its vote to the Executive Council. Any proposed amendment that has been laid over until the next Convention or referred to the Chapters may be reconsidered and voted upon at a later day at the same Convention.

SECTION 15.03. **Report on Amendment.** Amendments to the Bylaws shall be reported by the Secretary-Treasurer of the Association to each Collegiate and Alumnus Chapter, shall be printed in the official publications of the Association, and shall become the law of the Association.

SECTION 15.04. **Restriction.** These amending procedures shall apply to all Bylaws except Bylaw XV. This Bylaw may be amended only in accordance with Article XVIII of the Constitution.

## **Bylaw XVI**

### *Dissolution*

In the event of dissolution, the residual assets of the Association will be turned over to one or more organizations which are themselves exempt as organizations described in Section 501(c) (3) of the Internal Revenue Code of 1954 (or corresponding sections of any prior or future Internal Revenue Code), or to the Federal, State, or Local Government for exclusive public purposes, with preference to be given 501(c) (3) organizations.

INDEX TO CONSTITUTION  
AND BYLAWS

<i>Subject</i>	<i>Article &amp; Section</i>	<i>Subject</i>	<i>Article &amp; Section</i>
Advisory Board	C-VI, 7	action on communications	B-II, 2.02
Alumni eligibility	C-VIII, 4,5,7	Advisory Board	C-VI, 7
Alumnus chapter:		bylaws	C-VI, 5; B-V, 5.03
designation	C-II, 1	budget	B-V, 5.04
operations and		committees	B-V, 5.02
organization	C-VII	control	C-VI, 5
Alumnus member	C-VIII, 1	Convention assessments	B-I, 1.05
Amendment:		designation	C-II, 1
Bylaws	B-XV	discipline	C-IX
Constitution	C-XVIII	establishment	B-IV
Assessment, Convention	C-III; B-I, 1.05	finances	B-V, 5.04
Assistant Secretary-		financial accounts	B-V, 5.03
Treasurer:		fines	C-IX, 3
appointment of	C-IV, 2	initiation fee	B-V, 5.04
duties	B-III, 3.02	installation	C-VI, 4
retirement	C-IV, 2	meetings	C-VI, 9
salary	C-III, 5	member dues	B-VI, 6.08
Audit	B-III, 3.01	member election	B-VI
		member transfer	B-VI, 6.07
Badge:		membership	C-VI, 1
description	C-I, 3,4	officers	C-VI, 6
initiate	B-VII, 7.06	petition	B-IV, 4.01
BENT, THE:		probation	C-IX, 2
Life Subscription		proxy	C-VI, 8
Fund	C-X	quorum	B-V, 5.06
official publication	B-IX	roll book	B-VII, 7.05
prepaid subscriptions	C-XIII, 1	Colors	C-I, 3
Bond	C-IV, 5	Constitution:	
Budget, chapter	B-V, 5.04	amendment	C-XVIII
		custody	C-IV, 2
BULLETIN, THE:		enactment	C-XIX
official publication	B-IX, 9.01	interpretation	C-III, 2
publication & contents	B-IX, 9.03	reading by electees	B-VII, 7.03
Bylaws:		Contingency Fund	C-XIV
amendment	B-XV	Convention Fund	C-XII; B-I, 1.05
chapter	C-VI, 5	Convention:	
enactment	C-III, 2	assembly	B-I, 1.01
interpretation	C-III, 2	assessments	B-I, 1.05
reading by electees	B-VII, 7.03	Bylaws, suspension	B-I, 1.09
suspension	B-I, 1.09	Chair	C-III, 2; B-I, 1.02
Certificate:		committees	C-III, 2
fellowship	B-X, 10.05	delegate, alumnus chapter	C-VII, 4
membership	C-I, 3	delegates	B-I, 1.04
scholarship	B-XI, 11.05	Executive Council report	B-II, 2.03
Chapter— see alumnus chapter		frequency and composition	C-III, 2
or collegiate chapter		initiation, model	B-I, 1.07
Charter, issuance	B-III, 3.01	member privilege	B-I, 1.08
Collegiate Chapter:		minutes	B-I, 1.03
abolishment	C-III, 2	order of business	B-I, 1.02

<i>Subject</i>	<i>Article &amp; Section</i>	<i>Subject</i>	<i>Article &amp; Section</i>
proxy voting	B-I, 1.04	chapter actions on	
quorum	C-III, 2	communications	B-II, 2.02
rules	C-III, 2	composition	C-III, 3
rules of order	B-I, 1.10	election	C-III, 2
secretary	C-IV, 2	indemnification	C-IV, 4
special	C-III, 5	meetings and minutes	B-II, 2.01
voting	C-III, 2	nomination	C-III, 3
Councillor	C-III, 4	officers	C-III, 4
Creed	C-I, 9	responsibilities	C-III, 5
Currency	C-I, 11	take office	C-III, 3
		vacancies	C-III, 6
Deadlines	B-VIII, 8.04	Executive Director	C-IV, 1
Delegate:		Expense reports, Convention	
alumnus chapter	C-VII, 4	delegates	B-I, 1.06
collegiate chapter	B-V, 5.05	Expulsion, member	C-IX, 4, 5
expense	B-I, 1.06		
Director of Eng'g. Futures	B-III, 3.06	Faculty evaluation,	
Director of Fellowships	B-III, 3.04	member election	B-VI, 6.02
Director of Rituals	B-III, 3.03	Fee, initiation	B-V, 5.03(e)
Discipline:		Fellowships	B-X
appeal	C-III, 2	Fellowship Board	C-IV, 2
chapter	C-IX, 1.2	Fellowship Fund	C-XI
member	C-IX, 4, 5	Finances, chapter	B-V, 5.04
probation	B-VIII, 8.04	Financial inability	C-VIII, 10
Dissolution	B-XVI	Financial Review Committee	C-XVII, 8
Districts	C-II, 2	Fines, chapter	B-VIII
District Directors	C-IV; B-III, 3.05	Fiscal year	C-III, 7
		Flag	C-I, 3
Editor	B-IX, 9.02	Funds:	
Electee duties	B-VII, 7.02	administration	C-III, 5
Election:		BENT Life Subscription	C-X, B-IX
compilation of data	B-VI, 6.02	Contingency	C-XIV
financial inability	C-VIII, 10	Convention	C-XII
procedure	B-VI, 6.03	Engineering Futures	C-XV
records and reports	B-VI, 6.05	Fellowship	C-XI
relation to other org.	C-VIII, 8	Scholarship	C-XVI
revocation	B-VI, 6.04	Student Loan	C-XIII
Eligibility:		trustee	C-XVII, 2
alumni	C-VIII, 4, 5, 7		
eminent engineers	C-VIII, 6, 7	Governing bodies	C-III, 1
graduate students	C-VIII, 3	Graduate student:	
undergraduates	C-VIII, 2	election	B-VI, 6.03
Emblem	C-I, 3	eligibility	C-VIII, 3
Eminent Engineer:		member	C-VIII, 1
election	C-VIII, 6		
eligibility requirements	C-VIII, 7	Headquarters	C-II, 3
Employees:			
power to employ	B-III, 3.01	Inactive member status	B-VI, 6.06
retirement payments	C-V, 3	Indemnification of officers	C-IV, 4
Enactment, Constitution	C-XIX	Initiation:	
Engineering Futures	C-XV	approval	B-VI, 6.05
Executive Council:		by error	C-VIII, 11
bond	C-IV, 5	certificate and badge	B-VII, 7.06
		Const. and Bylaws reading	B-VII, 7.03

<i>Subject</i>	<i>Article &amp; Section</i>	<i>Subject</i>	<i>Article &amp; Section</i>
electee activities	B-VII, 7.01	Association	C-IV
electee duties	B-VII, 7.02	reports, Convention	B-I, 1.02
fee	B-VII, 7.04	vacancies	C-IV, 3
model, Convention	B-I, 1.07	Operating Fund	B-III, 3.01
postponement	B-VII, 7.09	Organization of Association	C-II
report	B-VII, 7.07		
roll book	B-VII, 7.05	Petition for chapter	C-VI, 2
unapproved fine	B-VIII, 8.02	President of Association	C-VI, 2
unapproved probation	C-IX, 2	Proxy:	
		chapter	C-VI, 8
Inspection	B-IV, 4.02	Convention	C-III, 2
Insignia	C-I, 3, 7	Publications	B-IX
Investment policy review	C-XVII, 8		
Investment requirements	C-XVII	Quorum:	
		chapter	B-V, 5.07
Jewelry, auxiliary	C-I, 5	Convention	C-III, 2
Joint meetings	B-VII, 7.08		
		Reports:	
Language	C-I, 10	chapter	B-V, 5.03
Laureates	B-XII	Fellow	B-X, 10.09
Life subscriptions	B-IX, 9.04	Executive Council	C-III, 5
Life Subscription Fund	B-IX, 9.05	Resignation	C-VIII, 9
Loan Fund	C-XIII	Retirement	C-V, 1
Loans, student	C-XIII; B-XII	Revocation of Election	B-VI, 6.04
		Ritual	C-I, 8
Meetings:		Roll Book	B-VII, 7.05
chapter	C-VI, 9	Rules of Order	B-I, 1.10
joint	B-VII, 7.08		
Member:		Scholarships	B-XI
alumnus	C-VIII, 1	Scholarship Fund	C-XVI
discipline	C-IX, 4, 5	Seal	C-I, 3
dues	B-VI, 6.08	Secretary-Treasurer:	
election	B-VI, 6.03	appointment of	C-IV, 2
graduate student	C-VIII, 1	duties	B-III, 3.01
inactive status	B-VI, 6.06	retirement	C-IV, 2
initiation	C-VIII, 1	salary	C-III, 5
undergraduate	C-VIII, 1	Secretary-Treasurers Emeritus	C-V, 4
Membership certificate:		Sigma Tau	C-XIX
form	C-I, 3	Student Loans	B-XII
issuance	B-VII, 7.06	Suspension, member	C-IX, 4
recall	C-VIII, 11	Symbol	C-I, 2
Minutes:			
Convention	B-I, 1.03	Transfer, chapter membership	B-VI, 6.07
Executive Council	B-II, 2.01	Trust Advisory Committee	C-XVI, 5
Motto	C I, 2	Trustee	C-XVI, 2
Name of Association	C-I, 1	Undergraduate member	C-VIII, 1
Officers:		Vacancies:	
bond	C-IV, 5	Executive Council	C-III, 6
chapter	C-VI, 6	officer	C-IV, 3
indemnification	C-IV, 4	Vice President of Association	C-IV, 2
investments by	C-XVI, 9	Vote, Convention	C-III, 2



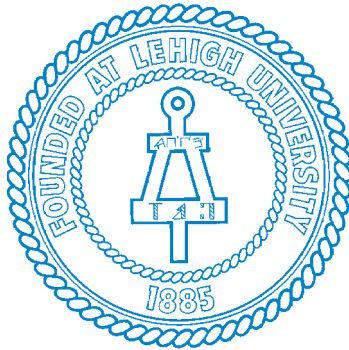

**Tau Beta Pi**  
**The Engineering Honor Society**

**Founded 1885**

*[www.tbp.org](http://www.tbp.org)*